

OPERATOR'S MANUAL

**FOR
CRUSHER, ROLL: DIESEL AND
ELECTRIC DRIVEN, WHEEL MOUNTED,
PNEUMATIC TIRES, 75 TON PER HOUR
EAGLE CRUSHER MODEL 5230B AND 5230C
(NSN 3820-00-788-5999)
EAGLE CRUSHER MODEL 5230D
(NSN 3820-00-876-7876)**

COMPONENT OF

**CRUSHING AND SCREENING
PLANT: DIESEL AND ELECTRIC DRIVEN,
WHEEL MOUNTED, 75 TON PER HOUR**

This manual supersedes TM 5-3820-205-10-1, dated 24 January 1964, and all changes.

Approved for public release distribution is unlimited.

HEADQUARTERS, DEPARTMENT OF THE ARMY

SAFETY PRECAUTIONS

BEFORE OPERATION

Always report or correct any conditions that may result in injury to personnel if operation is to be continued.

Before starting the engine or operating any of the roll crusher components, ensure that no loose bars, tools, or parts are laying in or on any part of the equipment as they could cause serious damage to the equipment or injury to personnel.

Before attempting to operate the equipment, make certain the roll crusher and the sources of power are properly grounded. Death by electrocution could result from improperly grounded equipment.

Never fill the fuel tank while the engine is running. Ensure that there are no open flames which may ignite the fuel vapor while filling the tank. Always provide a metal-to-metal contact between the fuel container and the fuel tank to avoid igniting the fuel vapors with a static spark.

Keep catwalks and decks free of grease, oil, ice, and mud to prevent slipping and falling. Use handrails to avoid falling from the roll crusher or into machinery.

When operating the roll crusher in an enclosed area, exhaust gases must be piped to the outside. The exhaust gases contain carbon monoxide which can be fatal if inhaled.

When servicing batteries, do not smoke or allow any flames or sparks in the vicinity. Batteries generate hydrogen, a highly explosive gas.

Battery acid (electrolyte) is extremely dangerous. Serious injury to personnel may result if battery acid contacts skin or eyes.

Do not operate the roll crusher with belt guards removed.

Ensure that all personnel are clear of the roll crusher before engaging the clutch or starting any of the components. Serious injury or death could result.

If NBC exposure is suspected, all engine air cleaner air filter media should be handled by personnel wearing protective equipment. Consult your NBC Officer or NBC for appropriate handling or disposal procedures.

DURING OPERATION

Always report or correct any conditions that may result in injury to personnel if operation is to be continued.

Do not continue operation of the equipment unless the roll crusher and the source of power are properly grounded. Death by electrocution could result from improperly grounded equipment.

Keep catwalks and decks free of grease, oil, ice, and mud to prevent slipping and falling. Use handrails to avoid falling from the roll crusher or into machinery.

Keep clear of moving machinery at all times to prevent injury.

Stop operation when cleaning, adjusting, or lubricating the components of the roll crusher.

Use extreme caution in removing the radiator cap from an overheated engine. Remove radiator cap slowly and only when engine is cool (below 120°F) or painful burns could result.

Do not add cold coolant to a hot engine or engine may be damaged. Allow engine to cool (below 120 °F) before adding coolant.

Never fill the fuel tank while the engine is running. Ensure that there are no open flames which may ignite the fuel vapor while filling the tank. Always provide a metal-to-metal contact between the fuel container and the fuel tank to avoid igniting the fuel vapors with a static spark.

Starting fluid is highly explosive and toxic. Handle starting fluid spray cans with extreme caution to prevent fire, explosion, and personal injury.

If NBC exposure is suspected, all engine air cleaner air filter media should be handled by personnel wearing protective equipment. Consult your NBC Officer or NBC for appropriate handling or disposal procedures.

AFTER OPERATION

Always report or correct any condition that may result in injury to personnel if operation is to be continued.

Stop operation when cleaning, adjusting, or lubricating the components of the roll crusher.

Never fill the fuel tank while the engine is running. Ensure that there are no open flames which may ignite fuel vapor while filling the tank. Always provide a metal-to-metal contact between the fuel container and the fuel tank to avoid igniting fuel vapors with a static spark.

Keep catwalks and decks free of grease, oil, ice, and mud to prevent slipping and falling. Use handrails to avoid falling from the roll crusher or into machinery.

Use extreme caution while removing the radiator cap from an overheated engine. Remove radiator cap slowly and only when engine is cool (below 120°F) or painful burns could result.

Do not add cold coolant to a hot engine or engine may be damaged. Allow engine to cool (below 120°F) before adding coolant.

**OPERATORS MANUAL
FOR CRUSHER, ROLL: DIESEL AND
ELECTRIC DRIVEN, WHEEL MOUNTED,
PNEUMATIC TIRES, 75 TON PER HOUR
EAGLE CRUSHER MODEL 5230B AND 5230C
(NSN 3820-00-788-5999)
EAGLE CRUSHER MODEL 5230D
(NSN 3820-00-876-7876)**

**COMPONENT OF
CRUSHING AND SCREENING
PLANT: DIESEL AND ELECTRIC DRIVEN,
WHEEL MOUNTED 75 TON PER HOUR**

REPORTING ERRORS AND RECOMMENDING IMPROVEMENTS

You can help improve this manual. If you find any mistakes or if you know of a way to improve the procedures, please let us know. Mail your letter, DA Form 2028 (Recommended Changes to Publications and Blank Forms), or DA Form 2028-2, located in the back of this manual, direct to: Commander, U.S. Army Tank-Automotive Command, ATTN: AMSTA-MB, Warren, MI 48397-5000. A reply will be furnished to you.

TABLE OF CONTENTS

	Paragraph	Page
CHAPTER 1. INTRODUCTION		
Section I. General	1,2	1
II. Description and data	3-6	1
CHAPTER 2. INSTALLATION AND OPERATION INSTRUCTIONS		
Section I. Service upon receipt	7-10	7
II. Controls and instruments	11,12	17
III. Operation of equipment	13-22	22
IV. Operation of auxiliary materiel used in conjunction with the roll crusher	23-25	30

* This manual supersedes TM 5-3820-205-10-1, dated 24 January 1964, and all changes.

TABLE OF CONTENTS (Con't)

	Paragraph	Page
CHAPTER 3. MAINTENANCE INSTRUCTIONS		
Section I. Operator's tools and equipment	26,27	31
II. Lubrication.....	28,29	31
III. Operator/crew preventive maintenance checks and services (PMCS)	30-32	32
IV. Troubleshooting procedures	33-49	37
V. Field expedient repairs	50-53	40
VI. Fuel system	54-57	40
VII. Cooling system	58,59	43
VIII. Engine electrical system	60,61	44
IX. Airbrake system	62,63	46
X. Exhaust system	64,65	47
XI. Engine clutch assembly	66,67	47
XII. Roll crusher assembly	68,69	47
XIII. Vibrating screen assembly	70-72	48
XIV. Feeder assembly	73,74	51
XV. Rotary elevator assembly	75,76	52
XVI. Return (under) conveyor assembly	77,78	53
XVII. Main (feed) conveyor assembly	79,80	54
XVIII. Leveling jacks	81,82	55
CHAPTER 4. DEMOLITION OF THE ROLL CRUSHER TO PREVENT ENEMY USE	83-87	57
Appendix I. REFERENCES		61
II. BASIC ISSUE ITEMS LIST		63
Index		71

CHAPTER 1 INTRODUCTION

Section I. GENERAL

1. Scope

a. These instructions provide information on the operation, lubrication, and preventive maintenance checks and services of the equipment, accessories, components, and attachments for the Eagle Roll Crusher Models 5230B, 5230C, and 5230D.

b. Appendix I contains a list of publications applicable to this manual. Appendix II contains the basic issue items authorized for use by the operator. The maintenance allocation chart is located in TM 5-3820-205-20- 1.

c. Numbers in parentheses on illustrations indicate quantity. Numbers preceding nomenclature callouts on illustrations indicate the preferred maintenance sequence.

d. You can help improve this manual. If you find an mistakes or if you know of a way to improve the procedures, please let us know. Mail your letter or DA Form 2028 (*Recommended Changes to Publications and, Blank Forms*) direct to: Commander, U.S. Army Tank Automotive Command, ATTN: AMSTA-MB, Warren, M 48397-5000. A reply will be furnished to you.

2. Maintenance, Forms, Records, and Reports

DA Forms and procedures used for equipment maintenance will be only those prescribed by DA Pam 738-750 *The Army Maintenance Management System(TAMMS)*.

Section II. DESCRIPTION AND DATA

3. Description

The Roll Eagle Crusher Models 5230B, 5230C, and 5230D (figs. 1 and 2) are portable, self-contained units used to crush and grade aggregate. A four cycle, six cylinder diesel engine operates the crusher roll assembly. Electric motors, driven by an extraneous power source, operate the vibrator screen assembly, return (under) conveyor, main (feed) conveyor, rotary elevator, and reciprocating feeder assembly. These components are described in appropriate sections of this manual.

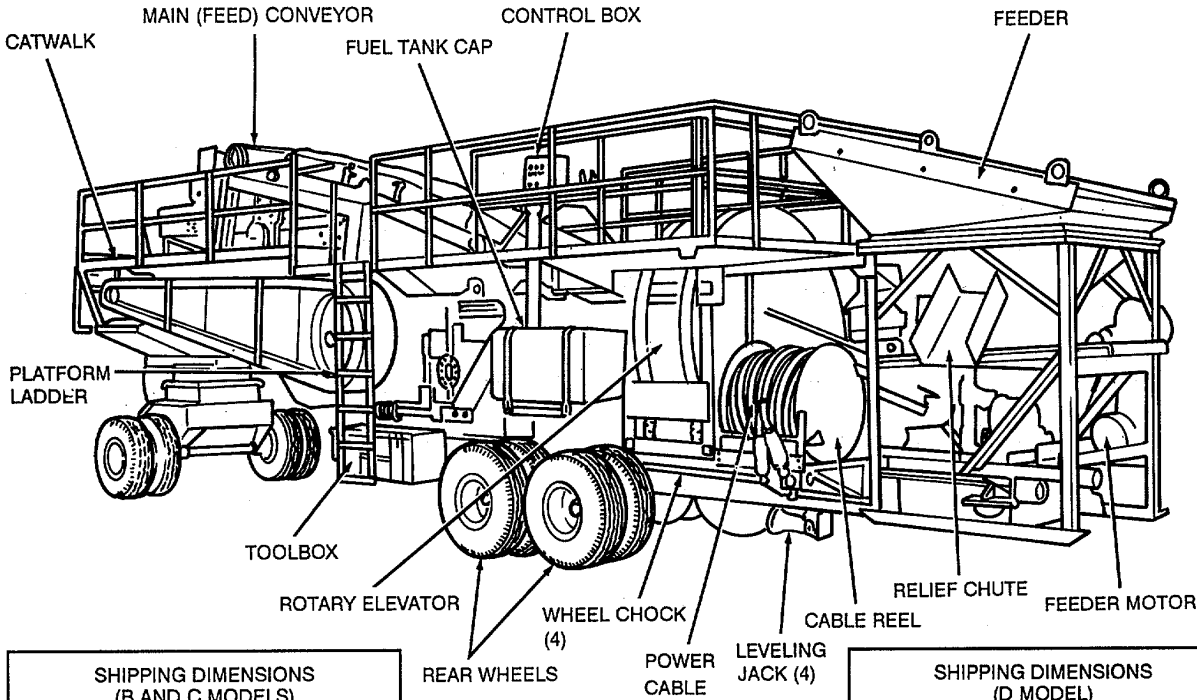

SHIPPING DIMENSIONS (B AND C MODELS)	
LENGTH	495 IN.
WIDTH	120 IN.
HEIGHT	143 IN.
WEIGHT	59,500 LBS
CUBAGE	4944 CU FT

SHIPPING DIMENSIONS (D MODEL)	
LENGTH	495 IN.
WIDTH	118 IN.
HEIGHT	146 IN.
WEIGHT	61,450 LBS
CUBAGE	4935 CU FT

Figure 1. Roll crusher, left rear, three-quarter view (Model 523B, C).

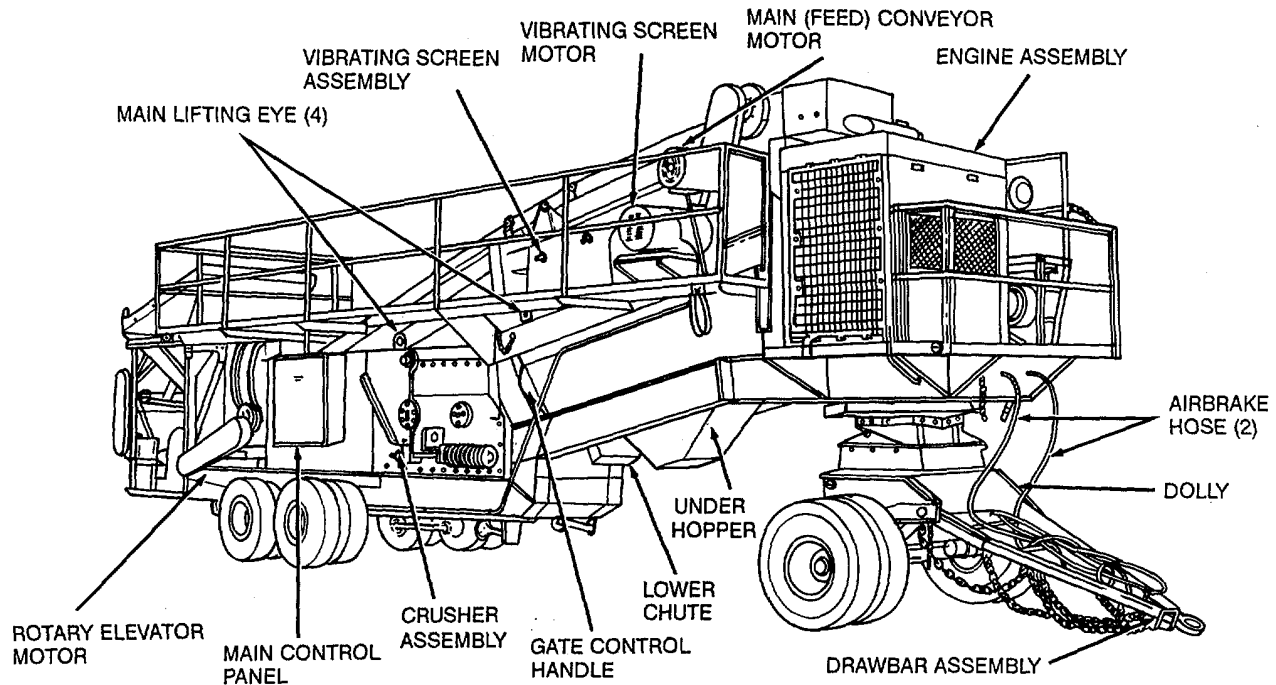

Figure 2. Roll crusher, right front, three-quarter view.

4. Aggregate Crushing and Screening Plant

The roll crushers shown on figures 1 and 2 may be a component of a crushing and screening plant. The plant must be set up on firm level ground and as near as possible to the source of material to be and positioned so the conveyors may expel the processed aggregate to the desired location for stock piling or hauling. Figure 3 illustrates a typical crushing and screening plant layout where the crusher may be utilized as a component. The positions of the various components may be changed as required. For example, only the final discharge conveyor is absolutely necessary for operation; the remaining three components indicated are illustrated only where the conveyors could be used at the operator's discretion. The power source can be either a generator set that will meet the requirements or powerline current. The direction of flow of the aggregate processed is also illustrated on figure 3.

5. Identification and Tabulated Data

a. *Identification.* The roll crusher has 15 major identification and instruction plates which are applicable to the operator.

- (1) *Corps of Engineers data plate.* Located on the left of the main frame of the trailer, below the vibrating screen assembly. Provides the National Stock Number, model number, and dimensions.
- (2) *Engine identification plate.* Located on the left side of the engine. Provides the manufacturer, model, and serial number.
- (3) *Power takeoff clutch identification and instruction data plate.* Located on top of the power takeoff housing at the rear of the engine. Provides the manufacturer, model, serial number, and operation, adjustment, and lubrication instructions.
- (4) *Transportation data plate.* Located on the left of the main frame of the trailer, below the vibrating screen assembly. Provides overall length, width, height, and center of gravity.
- (5) *Feeder, return (under) conveyor, and rotary elevator motor identification plates.* These plates are identical and are located on the motor housing. Provides manufacturer, model, horsepower, amps (amperes), volts, and rpm (revolutions per minute).
- (6) *Secondary trailer identification plate.* Located on the left of the main frame of the trailer. Provides the manufacturer and serial number.
- (7) *Dolly identification plate.* Located on the front of the dolly frame below the fifth wheel. Provides the manufacturer, model, and serial number.

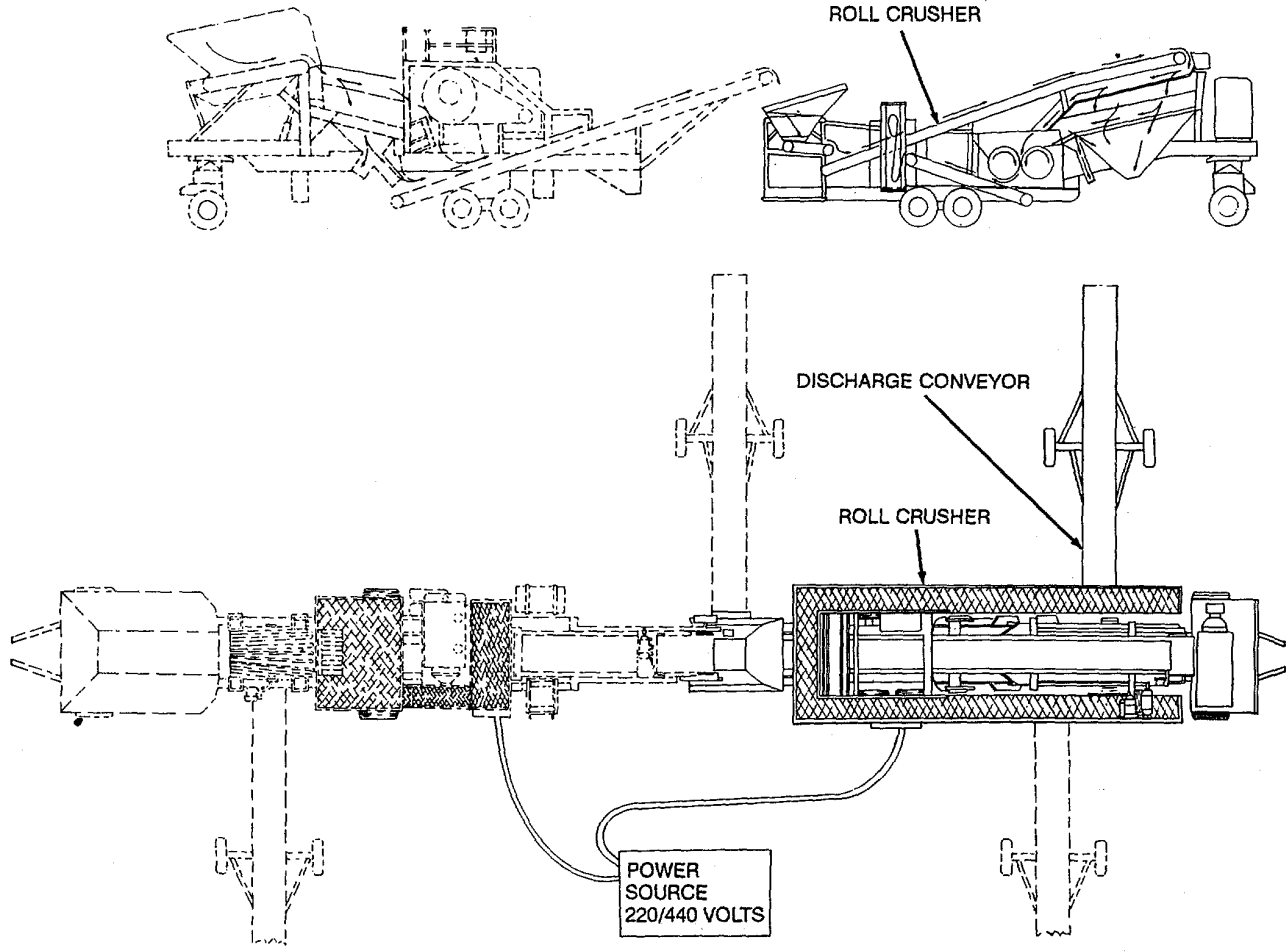

Figure 3. Aggregate flow diagram and typical crushing and screening plant layout.

TA507878

- (8) Vibrating screen identification. Located al the right of the vibrating screen assembly be hind the vibrating screen motor. Provides the manufacturer, serial number, and maximum speed.
- (9) Vibrating screen motor identification plate. Located on the vibrating screen motor housing Provides the manufacturer, model, and serial numbers and amps, volts, and cycles.
- (10) Main (feed) conveyor motor identification plate. Located on the conveyor motor housing. Provides the manufacturer, model, and serial numbers and amps, volts, and cycles.
- (11) Main (feed) conveyor gear reducer identification plate. Located on the conveyor gear reducer housing. Provides the manufacturer, class, horsepower, and ratio.
- (12) Rotary elevator and return (under) conveyor gear reducer identification plate. Located on the rotary elevator gear reducer housing. Provides the manufacturer, class, horsepower, and ratio.
- (13) Feeder gear reducer identification plate. Located on the feeder gear reducer housing. Provides the manufacturer, class, horsepower, and ratio.
- (14) Main control panel identification and data plate. Located inside the main control panel on the upper left-hand carrier. Provides the manufacturer, volts, phase, cycles, and serial number.
- (15) Main control panel caution plate. Located on the outside of the main control panel door. It states that a suitable ground rod and lead shall be installed at the power source before using the receptacles.

b. Tabulated Data.

(1) General

Manufacturer..... Eagle Crusher Co., Inc.
 Model 5230s, 5230C, and 5230D
 Type..... Roll Crusher
 Plant unit function Secondary
 Towing speeds:
 Over the road
 maximum 20 mph (miles per hour)
 Cross-country maximum 10 mph

(2) Engine

Manufacturer..... Cummins Engine Co., Inc.
 Model N855/P235
 Specification number DS-4217
 Type..... Diesel
 Cycle..... 4
 Number of cylinders..... 6
 Rated horsepower 195hp (horsepower) at 1800 rpm
 (revolutions per minute)
 Oil pressure 50-70psi(pounds per square inch)
 at 1800 rpm
 Brake horsepower 235 hp at 2100 rpm Cooling
 system:
 Type..... liquid
 Temperature range 175°F-195°F

Electrical System:
 Operating voltage..... 24 volts
 Number of batteries 4 (series parallel connected)
 Type of batteries Storage, 12 volt, 6 cell (type
 designation 6TN)
 Type of ground..... Negative

Air cleaner-type Dry
 Clutch-type..... Friction, dry, positive-action

(3) Roll crusher assembly

Manufacturer..... Eagle Crusher Co., Inc.
 Model 24 x 30
 Size of discharge opening..... 1/4-3 in.
 Revolutions per minute
 (mainshaft speed)..... 300

(4) Vibrating screen assembly

Manufacturer..... Allis-Chalmers Manufacturing Co.

Model.....S
 TypeRipl-flo
 Size 4 x 10 DD
 Maximum speed.....900 rpm

(5) Reciprocating feeder

ManufacturerEagle Crusher Co., Inc.
 Model.....4517 (Models 5230B, 5230C) and
 4517A (Model 5230D)
 Capacity (24 in.).....175 tph (tons per hour)

(6) Rotary elevator

ManufacturerEagle Crusher Co., Inc.
 Model.....4601 (Models 5230B, 5230C) and
 4601B (Model 5230D)
 Size72 in. die (diameter) x 24 in. w
 (wide)

(7) Main (feed) conveyor

ManufacturerEagle Crusher Co., Inc.
 Model.....5031 (Models 5230B 5230C) and
 5031A (Model 5230D)
 Capacity.....175 tph
 Belt width.....24 in.

(8) Return (under) conveyor

ManufacturerEagle Crusher Co., Inc;
 Model.....30288 (Models 5230B, 5230C) and
 4715 (Model 5230D)
 Capacity.....175 tph

(9) Trailer

ManufacturerFruehauf Trailer Co.
 Model.....Secondary trailers

(10) Dolly

ManufacturerFruehauf Trailer Co.
 Model.....5930 (Models 5230B, 5230C) and
 5930B (Model 5230D)

(11) Feeder, return (under) conveyor, and rotary elevator motors

ManufacturerGeneral Electric Corp.
 Model.....5KG215BG202
 TypeKG
 Horsepower5
 Revolutions per minute1745

Volt 208-220/440
 Phase 3
 Cycle 60
 Amperes 14.2/7.1
 Time rating Continuous

(12) vibrating screen motor

Manufacturer General Electric Corp.
 Model 5KG4284B2
 Type KG
 Horsepower 15
 Revolutions per minute 1755
 Volt 208-220-440
 Phase 3
 Cycle 60
 Amperes 40.8120.4
 Time rating Continuous

(13) Main (feed) conveyor motor

Manufacturer General Electric Corp.
 Model SKG4256B2
 Type KG
 Horsepower 10
 Revolutions per minute 1745
 Volt 208-220/440
 Phase 3
 Cycle 60
 Amperes 27.4/13.7
 Time rating Continuous

(14) Main (feed) conveyor year reducer

Manufacturer Reliance Electric Co.
 Model 1X1415
 Class 1
 Horsepower 16.9 hp at 1750 rpm
 Ratio 15:1

(15) Return (under) conveyor year reducer

Manufacturer Reliance Electric Co.
 Model TXT415
 Class 1
 Horsepower 11.1 hp at 1750 rpm
 Ratio 15:1

(16) Performance data

Vibrating screen grade
 aggregate sizes. 1/4-2 1/2 in.
 Crusher rolls aggregate sizes. 1/4-3 in. discharge size
 Conveyor belt width 24 in.

(17) Adjustment data

Defector (hopper loaded)
 and belt scrappers Barely touch conveyor belt.
 Conveyor belt Just enough to prevent slipping
 when loaded.
 Electric motor drive belts 1/2 in. deflection midway between
 pulleys.
 Roll adjusting spring 23 in.

(18) Capacities

Air cleaner dry
 Radiator 64 qt (quarts)
 Oil:
 Crankcase only 28 qt
 Oil filter (bypass) 0.7 qt
 Oil filter (full-flow) 2 qt
 Fuel tank 100 gal. (gallons)
 Upper conveyor gear reducer ... S qt
 Under conveyor gear reducer ... 4 qt
 Feeder shaft gear reducer 2 qt
 Elevating wheel gear reducer ... 2 qt
 Roll crusher gearcase 92 qt
 Tires 100 psi

(19) Dimensions and weights

5230B, 5230C:
 Overall length 495 in.
 Overall width 120 in.
 Overall height 143 in.
 Weight 59, 500 lb (pounds)
 Cubage 4944 cu ft (cubic feet)
 Center of gravity 72 in. above ground level, 89 in.
 forward between center of bogie
 wheels.
 5230D:
 Overall length 495 in.
 Overall width 118 in.
 Overall height 146 in.
 Weight 61, 450 lb
 Cubage 4935 cu ft
 Center of gravity 74 in. above ground level, 87 in.
 forward between center of bogie
 wheels.

6. Differences Between Models

This manual covers Eagle Roll Crusher Models 5230B, 5230C, and 5230D. Where differences exist between the serial number ranges, the serial number range is specified in the applicable section of this manual.

CHAPTER 2

INSTALLATION AND OPERATION INSTRUCTIONS

Section I. SERVICE UPON RECEIPT

7. Unloading the Roll Crusher

The operator may assist in unloading the roll crusher from the common carrier. The operator will help remove the tie-down cables, strapping, blocking, etc. which secure the roll crusher on the carrier. Organizational maintenance will perform the remaining operations.

8. Inspecting and Servicing Equipment

Note: Ensure that the roll crusher is completely deprocessed before servicing. Ensure that preservatives have been removed from such items as crankcase, fuel tank, and gearboxes.

- Perform the Operator/Crew Preventive Maintenance Checks and Services (para 32).
- Make a complete visual inspection to see that required tools, repair parts, publications, accessories, and attachments are with the roll crusher and are in serviceable condition.
- Visually inspect the roll crusher for loss of parts or damage which may have occurred during loading, shipping, or unloading.
- Report all damage and deficiencies to organizational maintenance.
- Refer to Table 1 for a complete list of the maintenance and operating supplies required for initial operation of the roll crusher.

9. Installation or Setting-Up Instructions

- Locate the roll crusher on a flat or leveled surface. If necessary, use any suitable equipment such as a bulldozer to level the site. Plan the site so there will be no obstruction to trucks or other hauling vehicles going to and from the plant. Refer to figure 3 for suggested placement of plant components. After the roll crusher is located, level the area immediately under the roll crusher frame for cribbing.
- Remove the wheel chocks (fig. 4) from their brackets on the main frame above the rear wheels and securely block the rear wheels (fig. 5).

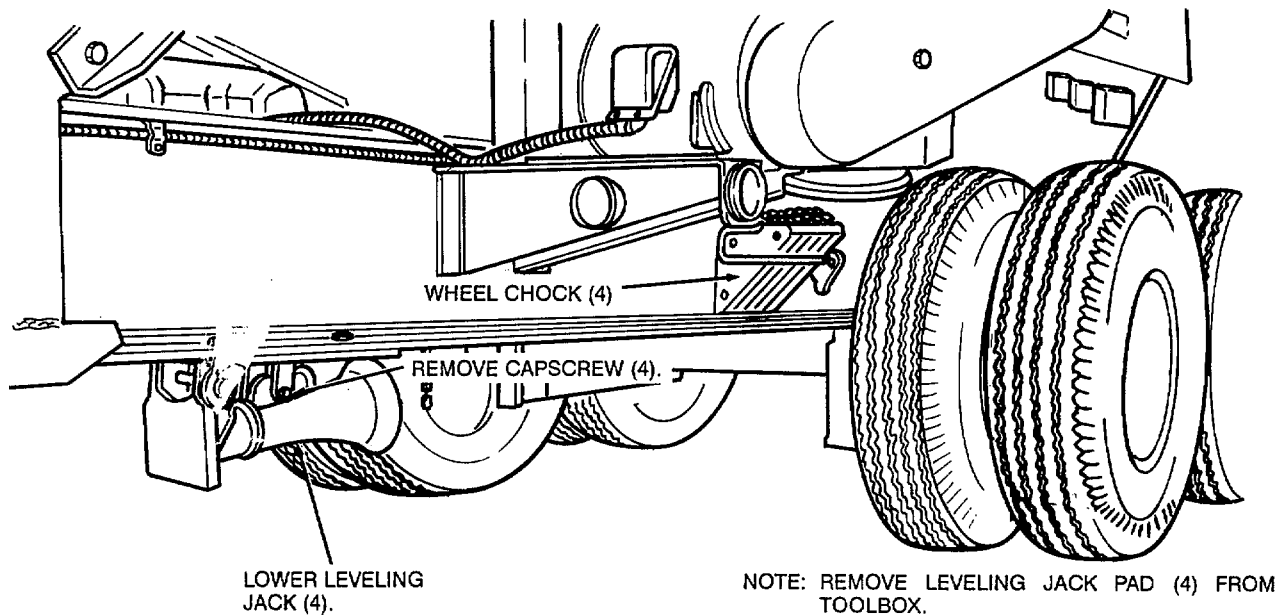

Figure 4. Leveling jacks and wheel chocks, stowed position.

TA507879

Table 1. Maintenance and Operating Supplies

(1) Item	(2) Component Application	(3) National Stock No.	(4) Description	(5) Quantity Required for Initial Operations	(6) Quantity Required for 8 Hours Operations	(7) Notes
1	0101 CRANKCASE	9150-00-189-6729 (2) 9150-01-152-4119 (2) 9150-00-186-6685 (2) 9150-00-491-7197 (2)	OIL, LUBRICATING: 55 gal. drum as follows: OE/HDO 30 OE/HDO 15/40 OE/HDO 10 OEA	30 qt (1) 30 qt (1) 30 qt (1) 30 qt (1)	(3) (3) (3) (3)	(1)Includes quantity of oil to fill engine system as follows: Crankcase-28 qt Full-flow-2 qt Bypass-0.7 qt (2) See TB 703-1 for additional data and requisitioning procedure. (3) See LO 5-3830-905-12-1. for grade application and replenishment intervals. (4) Tank capacity.
2	0306 TANK, FUEL	9140-00-286-5283 (2) 9140-00-286-5286 (2) 9140-00-286-5294 (2)	FUEL OIL, DIESEL bulk as follows: DF-A DF-1 DF-2	100 gal. (4) 100 gal. (4) 100 gal. (4)	76 gal. (5) 76 gal. (5) 76 gal. (5)	(5) Average fuel consumption is 9.5 gal. per hour of continuous operation. (6) Refer to organizational maintenance for quantities, ambient temperature, specific gravities, and replenishment
3	0311 ENGINE STARTING AIDS	6850-00-823-7861	STARTING FLUID: spray can	1 can		
4	0501 RADIATOR	6850-00-181-7940 6850-00-174-1806	WATER ANTIFREEZE 55 gal. drums as follows: Ethylene Glycol Compound Arctic	64 qt	(6)	
5	7506 GEAR ASSEMBLY CONVEYOR DRIVE RETURN CONVEYOR GEAR REDUCER		OIL, LUBRICATING (3) OIL, LUBRICATING (3)	5 qt 4 qt	(3) (3)	
6	7508 ELEVATING WHEEL GEAR REDUCER		OIL, LUBRICATING (3)	2 qt	(3)	
7	7512 GEAR ASSEMBLY, FEEDER DRIVE		OIL, LUBRICATING (3)	2 qt	(3)	
8	7520 CRUSHER FRAMES		OIL, LUBRICATING GEAR: 55 gal. drum as follows: GO 85W/140 GO 80W/90	92 qt 92 qt	(3) (3)	
9	GREASE POINTS	9150-00-035-5396 9150-01-035-5394 9150-01-035-5391 9150-01-197-7692	5 gal. drum as follows: GO 75W GREASE, AUTOMOTIVE AND ARTILLERY: 35 lb. pail: GAA	92 qt 4 lb	(3) 1 lb	

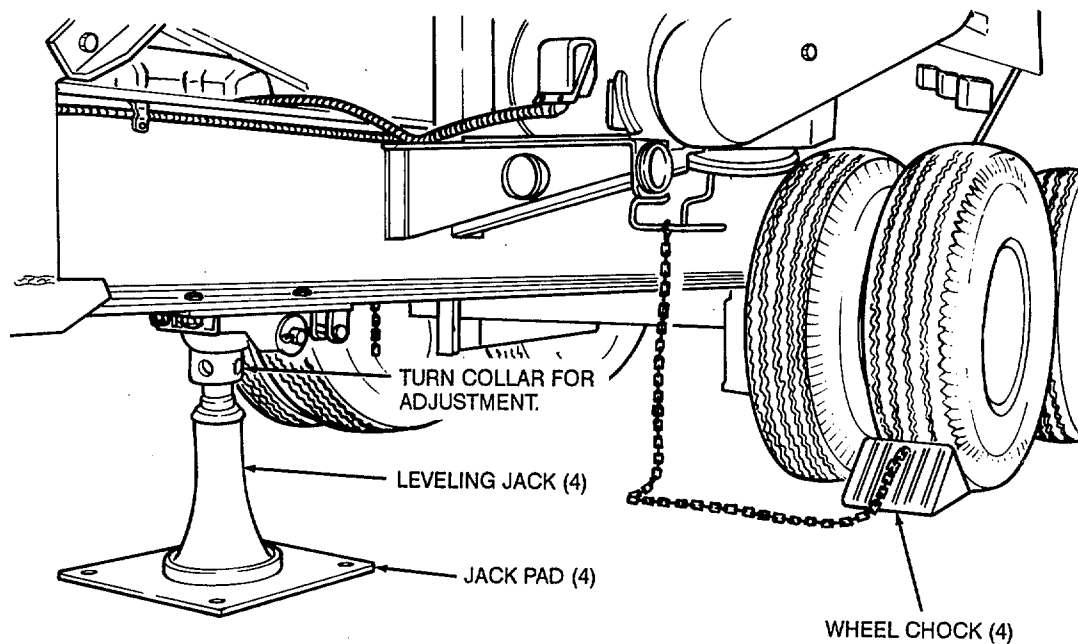

Figure 5. Leveling jacks and wheel chocks installed position.

c. The roll crusher is equipped with four mounted screw-type leveling jacks. Lower the leveling jacks (fig. 4) and position the jacks into the jack pad recess (fig. 4). If the ground is soft or provides a poor bearing surface, place timbers or other suitable supports under the jack pads.

Caution: Install the leveling jacks and cribbing so that roll crusher will be level both lengthwise and crosswise, and the weight of the roll crusher is removed from the wheels and axles. Inaccurate leveling may cause the drive belts and conveyor belts to run off, material to travel to one side of screens, and rubber mountings of the vibrating screen to twist, resulting in damage to equipment.

d. Level the trailer frame. Check in several places to avoid having a twist or sag in the frame. Adjust the jacks accordingly. Accuracy in leveling is very important, because an improperly leveled roll crusher unit may cause the drive belts and conveyor belts to run off, material to travel to one side of screens, and rubber mountings of the vibrating screen to twist.

e. Crib the roll crusher by raising the front end with the leveling jacks, keeping the crusher level, and build the cribbing solidly up to the frame. Screw the leveling jacks back a few turns, allowing the weight to rest on the cribbing. Crib under the rear end of the roll crusher frame in a similar manner.

f. Remove the drawbar jack from stowed position (fig. 6). Install the drawbar jack (fig. 7) (on units of equipment within serial number range 6590 through 6629).

g. Position the discharge conveyor of the crushing and screening plant (fig. 3).

Warning: Do not connect electrical power or operate the equipment if the ground connection is not properly installed (fig. 8). Death by electrocution could result from improperly grounded equipment.

h. Install the ground rod (fig. 8).

i. Remove the main power cable and the feeder jumper cable from their reels (figs. 9 and 10).

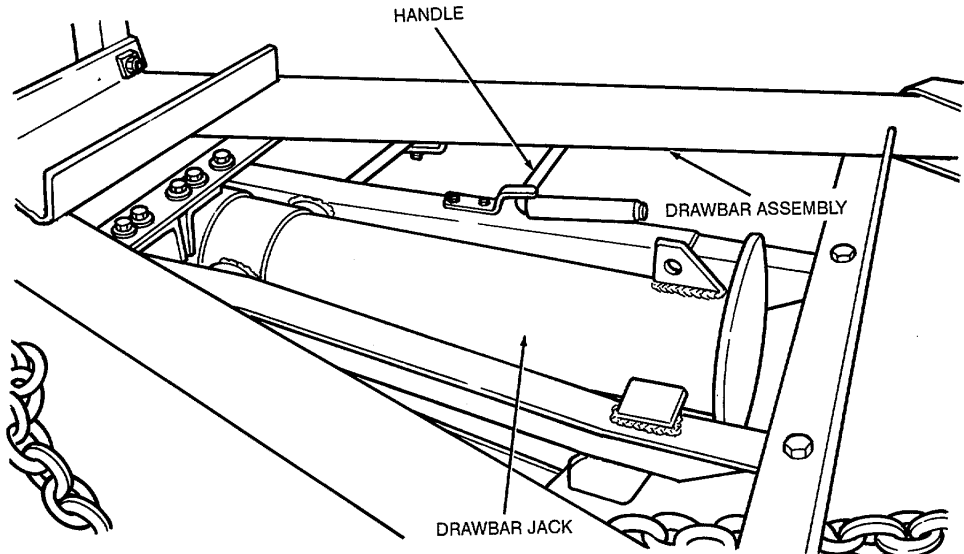

Figure 6. Drawbar leveling jacks, stowed position, serial numbers 6590 through 6629.

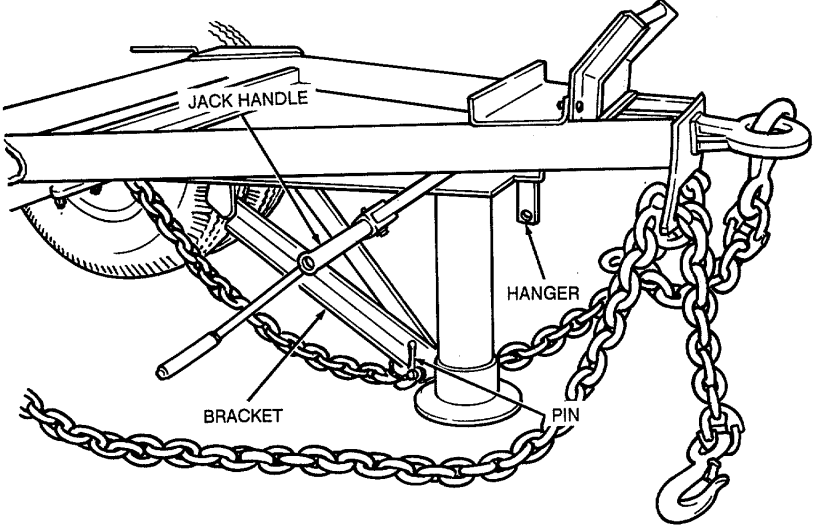

Figure 7. Drawbar leveling jack, installed position, serial numbers 6590 through 6629.

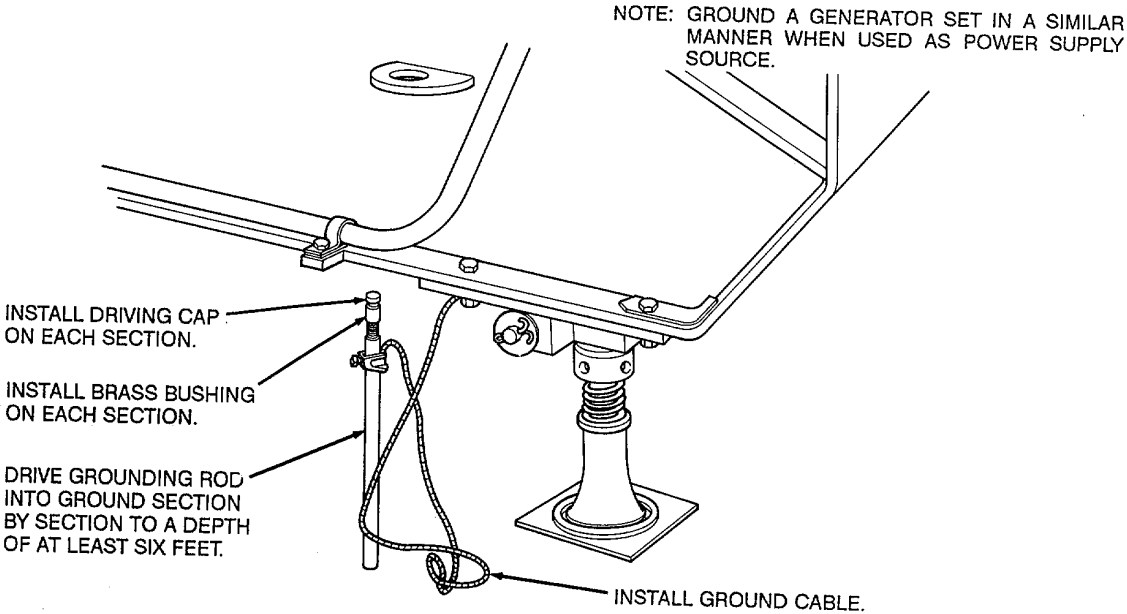

Figure 8. Grounding the roll crusher.

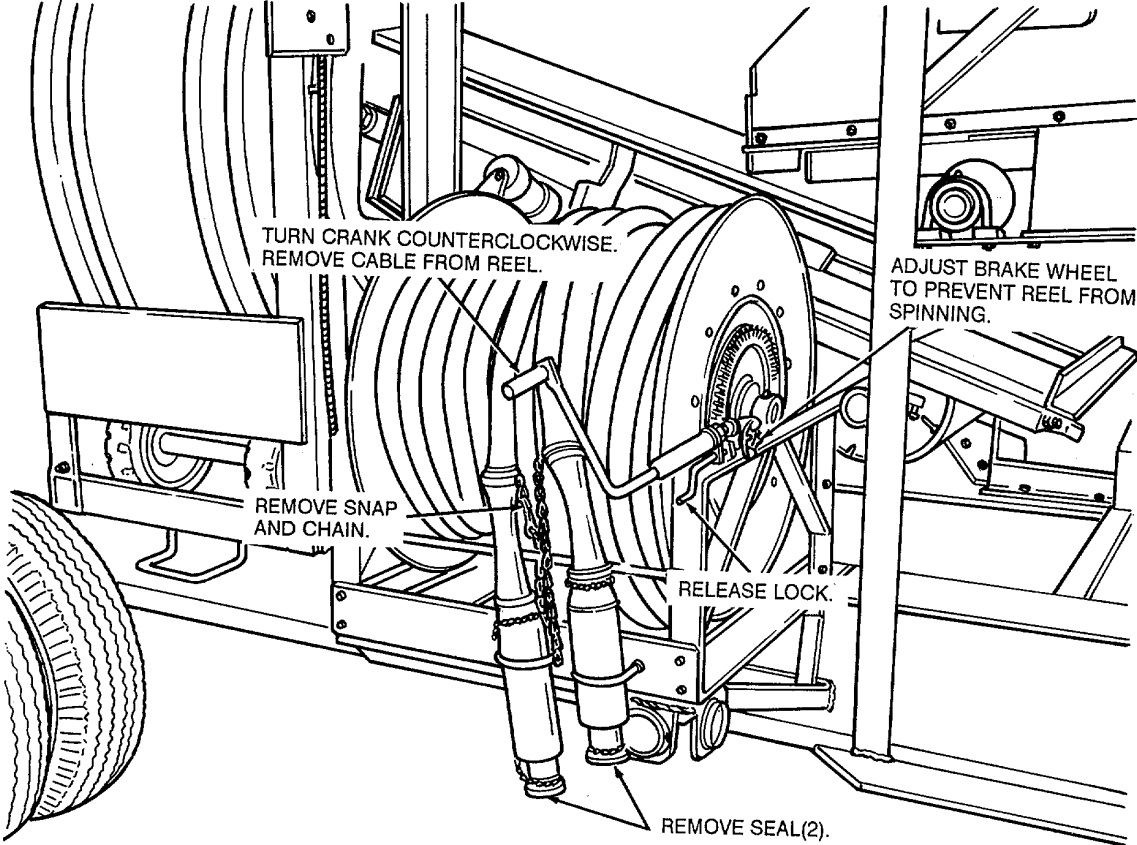

Figure 9. Main power cable installed on reel.

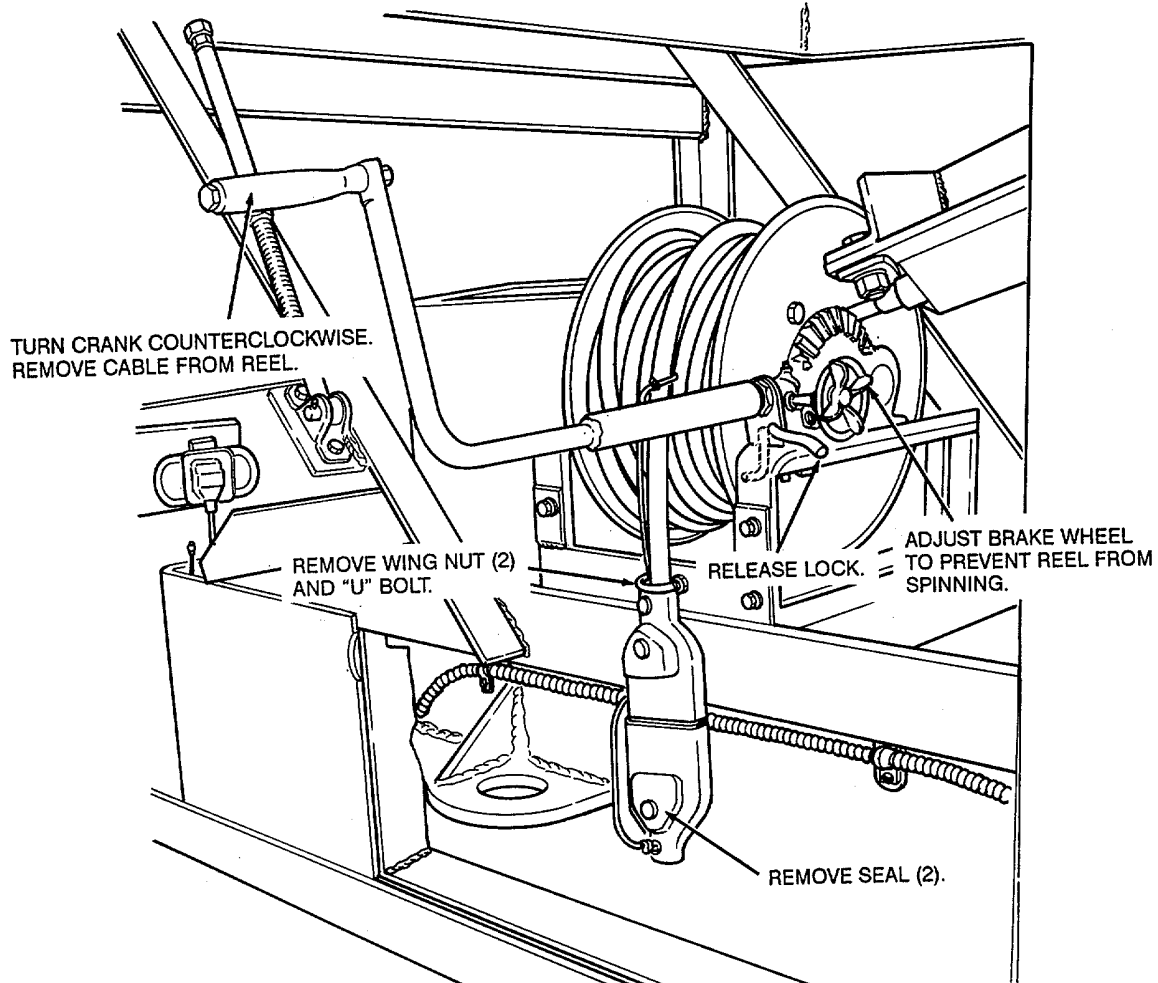

Figure 10. Feeder jumper cable installed on reel.

Warning: Ensure that roll crusher and power source are properly grounded before connecting the short main power cable to the power source. Death by electrocution could result from improperly grounded equipment.

- j. Connect the side conveyor cable and feeder jumper cable to the control panel, and connect the main power cable to the control panel and main power source (figs. 11 and 12).
- k. Connect the feeder jumper cable to the feeder motor (fig. 13).
- l. Remove the feeder relief chute extension from stowed position (fig. 14). Install the feeder relief chute extension on the feeder relief chute (fig. 15).

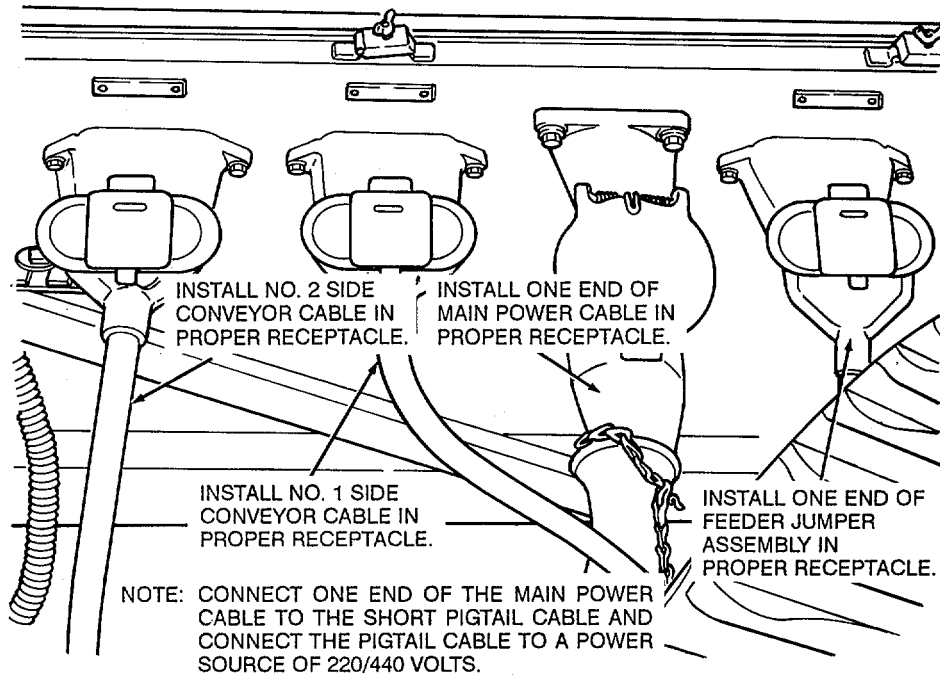

Figure 11. Cables installed on main control panel

NOTE: CONNECT ONE END OF THE MAIN POWER CABLE TO THE SHORT PIGTAIL CABLE AND CONNECT THE PIGTAIL CABLE TO A POWER SOURCE OF 220/440 VOLTS.

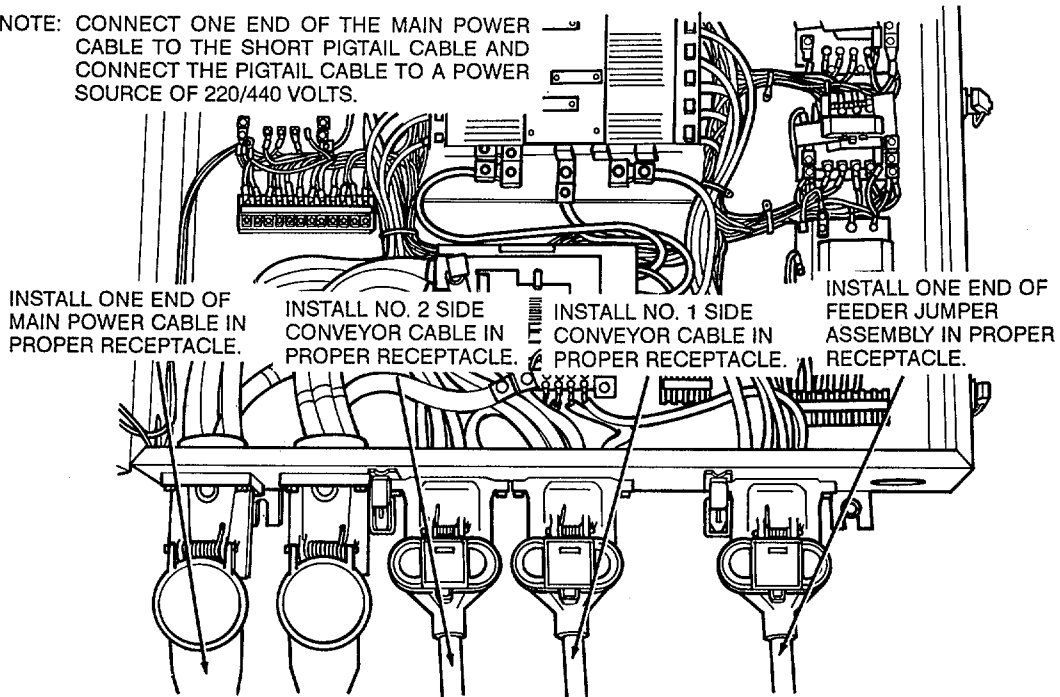

Figure 12. Cables installed on main control panel (Model 5230D).

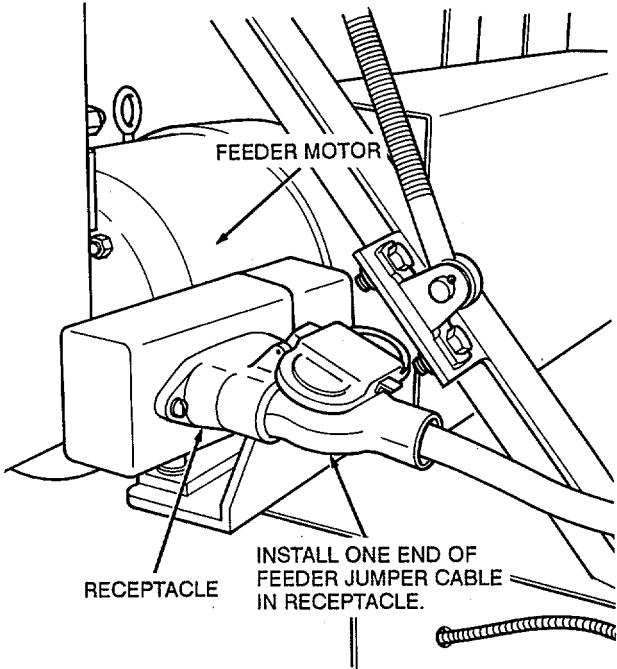

Figure 13. Feeder jumper cable installed on motor.

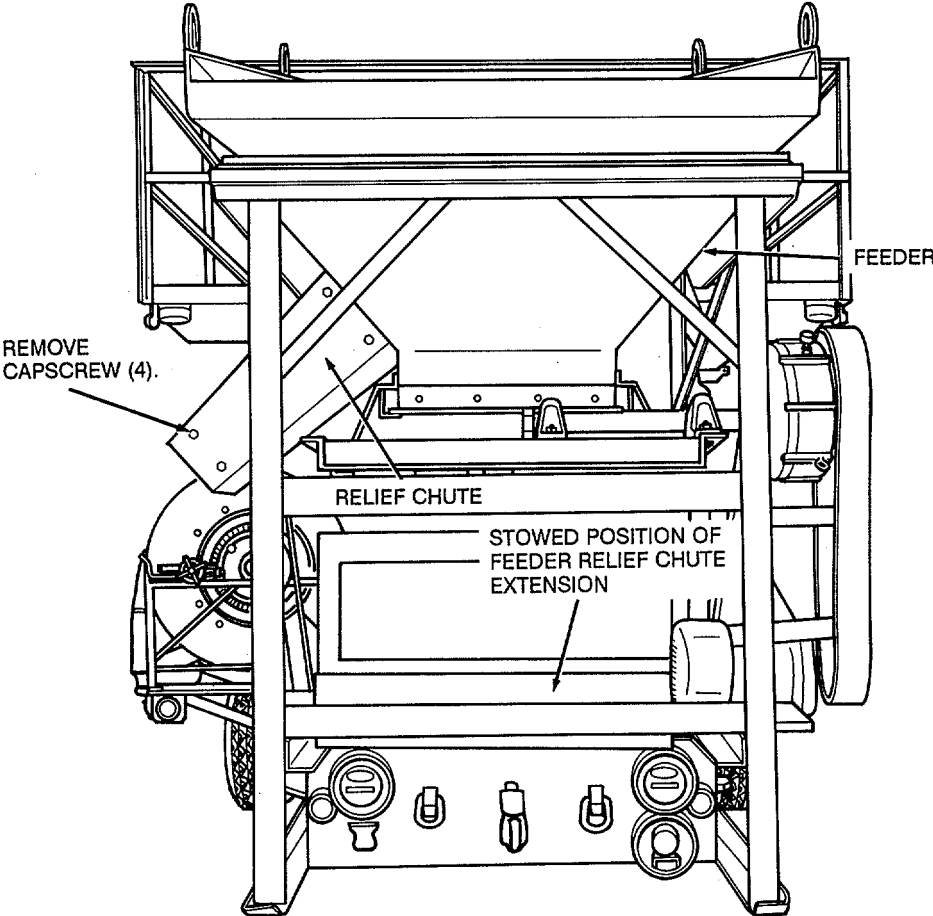

Figure 14. Feeder relief chute extension, stowed position.

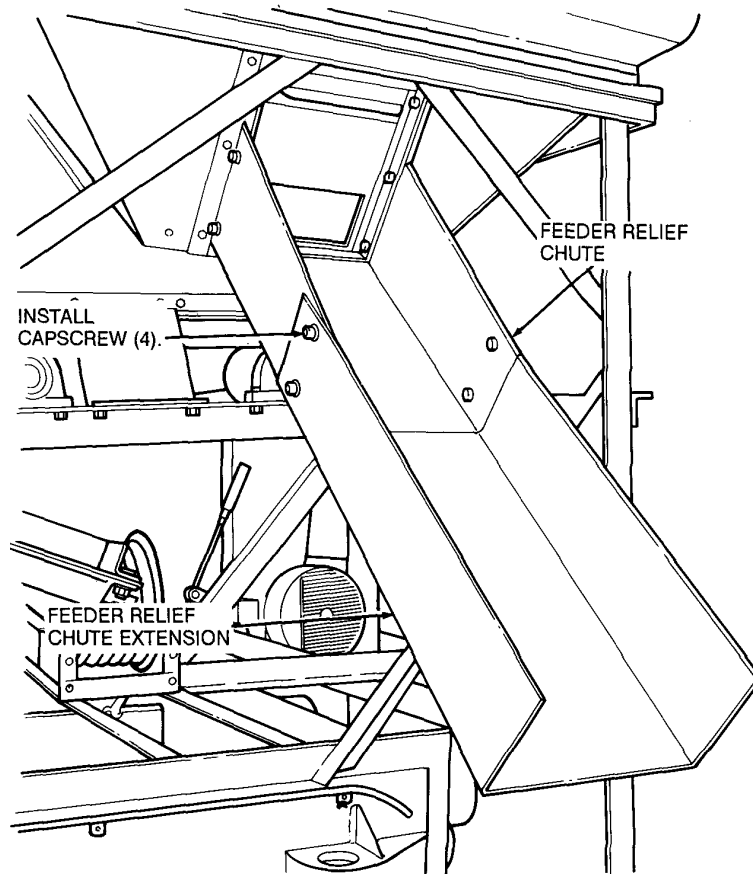

Figure 15. Feeder relief chute extension, installed position.

- m.* Open the main control panel door and move the circuit breakers to the ON position (figs. 16-18).
- n.* Install the air cleaner channel holding bracket. Position the air cleaner extension tubing with clamps. Install the precleaner (fig. 54).

10. Movement to a New Worksite

- a.* Remove all aggregate material from the conveyor belts, hoppers, and crusher.
- b.* Disconnect the main power cable and the short main power cable from the power source, and disconnect all cables from the control panel in reverse of the instructions on figures 11 and 12.
- c.* Remove the feeder jumper cable from the feeder motor in reverse of the instructions on figure 13.
- d.* Install the feeder jumper cable on the reel in reverse of the instructions on figure 10.
- e.* Remove the ground cable in reverse of the instructions on figure 8.
- f.* Install the main power cable on the reel in reverse of the instructions on figure 9 and stow the short main power cable in the toolbox.
- g.* Remove other components of the crushing and screening plant clear of the roll crusher.
- h.* If the dolly has been removed, report to organizational maintenance for dolly installation.
- i.* Raise the roll crusher with the jacks and remove all cribbing.
- j.* Remove and stow the landing jacks and wheel chocks in reverse of the instructions on figure 4. Stow the landing jack pads in the toolbox (fig. 1).
- k.* Remove the feeder chute extension and stow the extension in reverse of the instructions on figure 14.
- l.* Remove roll crusher electric cable connector and airbrake hoses from the toolbox and install on roll crusher (fig. 2).

TA507886

CAUTION: OPEN THE MAIN CONTROL PANEL DOOR ONLY FOR MAINTENANCE OR FOR SETTING CIRCUIT BREAKERS.

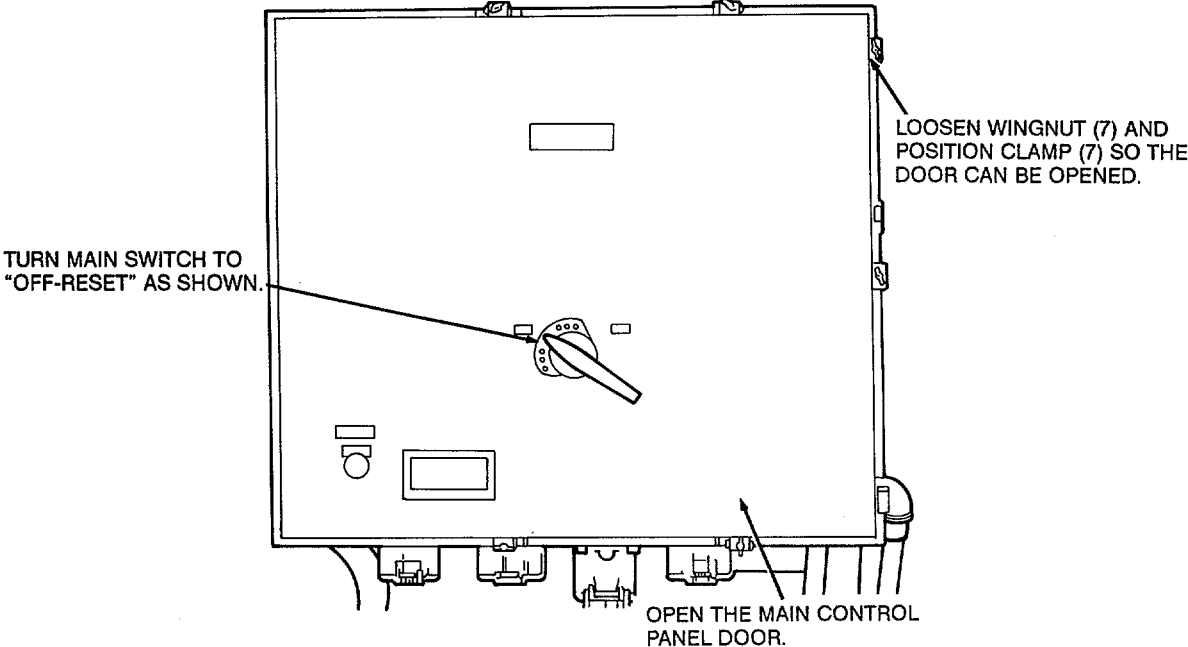

Figure 16. Actuating the roll crusher electrical system.

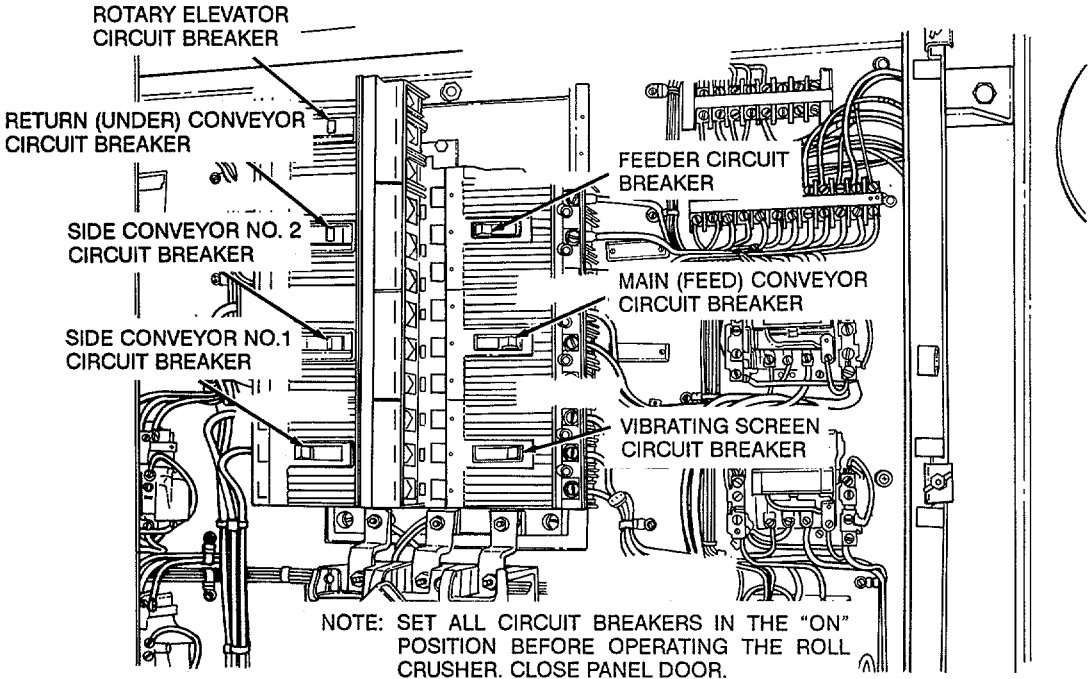

Figure 17. Main control panel circuit breakers.

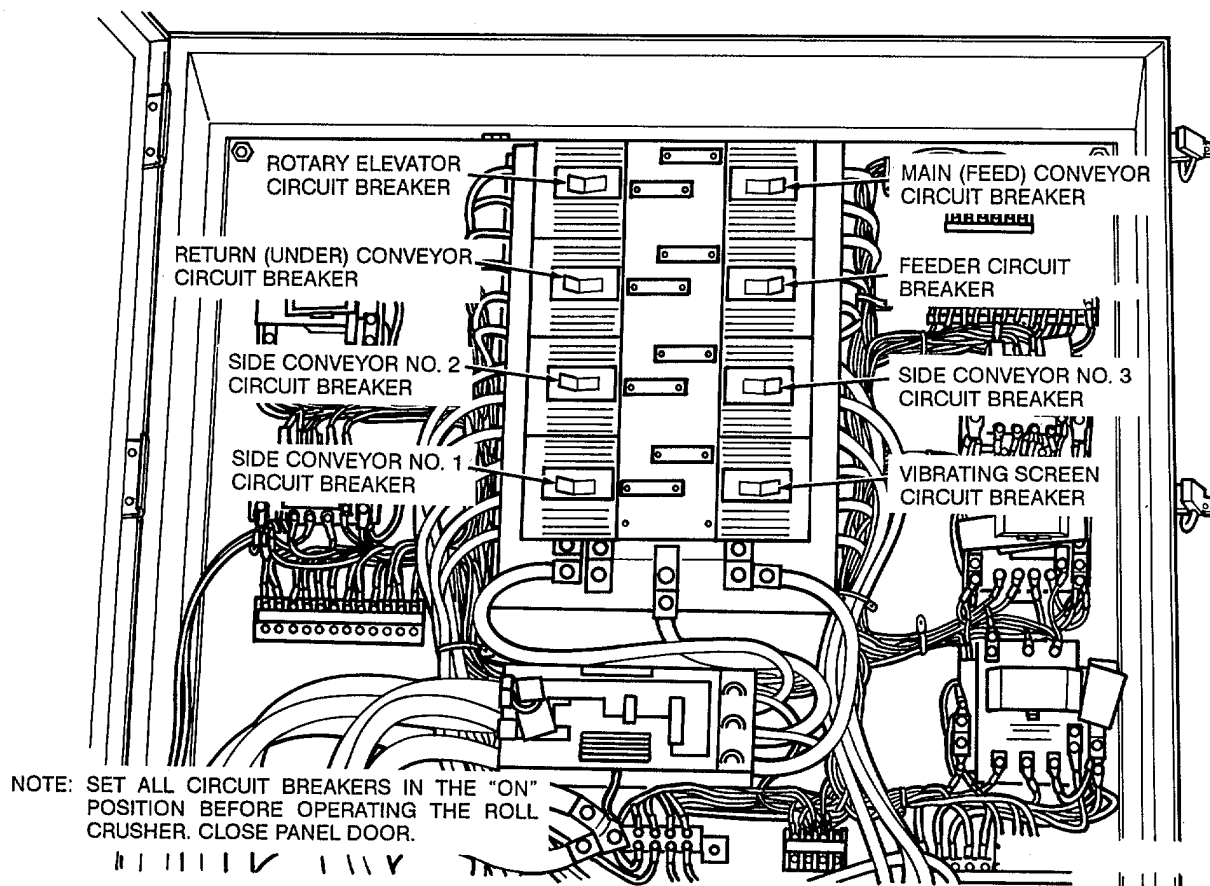

Figure 18. Main control panel circuit breakers (Model 5230D).

Caution: Do not exceed 20 mph on good hard surface road or 10 mph on secondary roads or cross-country when towing the roll crusher.

- m. Attach suitable towing vehicle to the roll crusher, remove the wheel chock and stow them in the bracket on the frame (fig. 4).
- n. Install and set up the roll crusher (para 9). Install precleaner, air cleaner extension tubing with clamps, and air cleaner channel holding bracket (fig. 54).
- n. Install and set up the roll crusher (para 9). Install precleaner, air cleaner extension tubing with clamps, and air cleaner holding bracket (fig. 43).

Section II. CONTROLS AND INSTRUMENTS

11. General

This section describes, locates, illustrates, and furnishes the operator or crew sufficient information about the various controls and instruments for proper operation of the roll crusher.

12. Controls and Instruments

Caution: Operator's switch boxes must be properly closed and sealed to prevent water from entering the box and causing switches and controls to corrode and become unserviceable. All control boxes should be examined to assure that doors are properly sealed and closed tight.

The purpose, location, use of the controls, and normal readings of the instruments and gages are illustrated on figures 19-28.



Figure 19. Fuel gage.

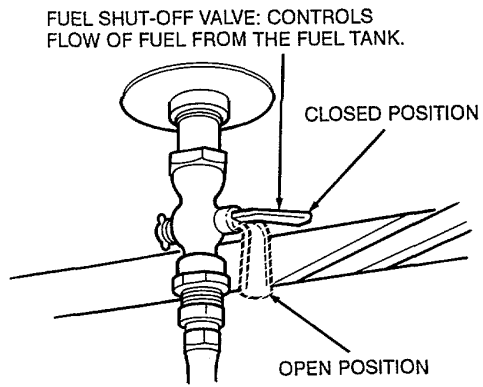

Figure 20. Fuel shut-off valve.

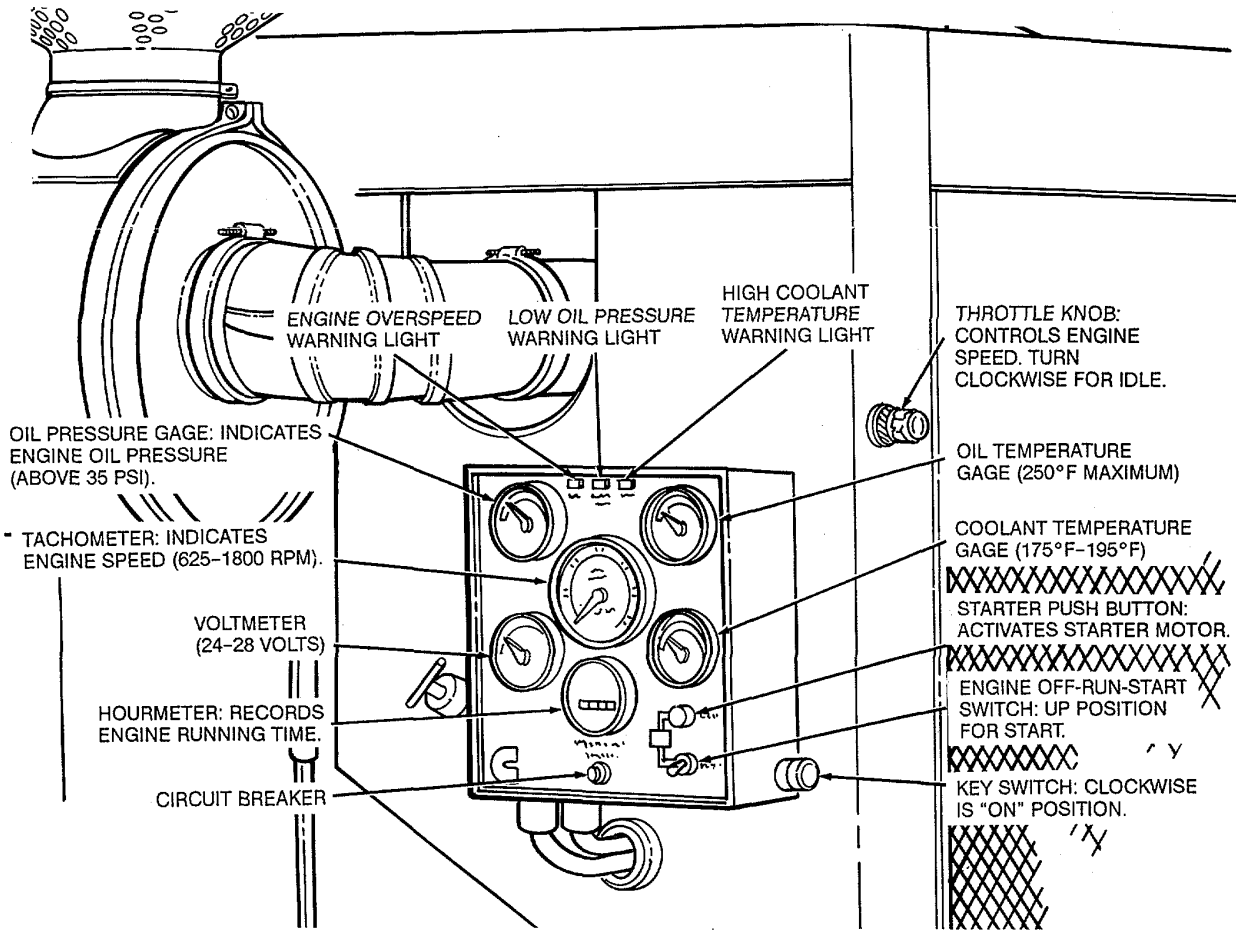

Figure 21. Engine indicator panel and throttle knob.

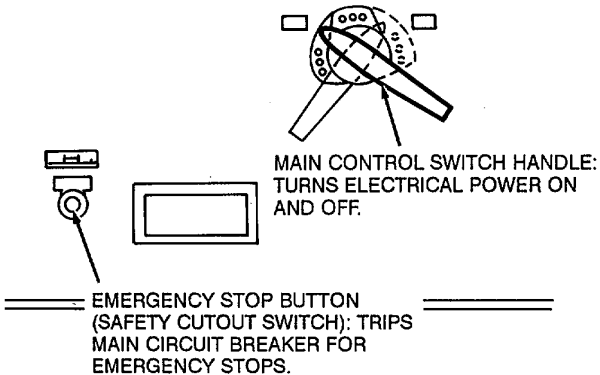

Figure 22. Emergency stop button and main control switch handle.

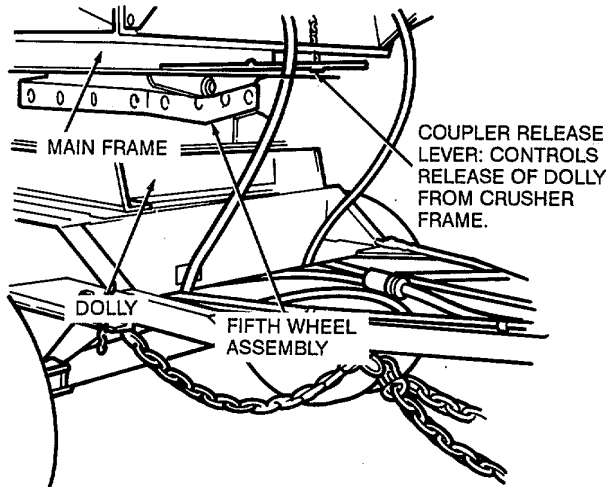

Figure 23. Fifth wheel coupler control.

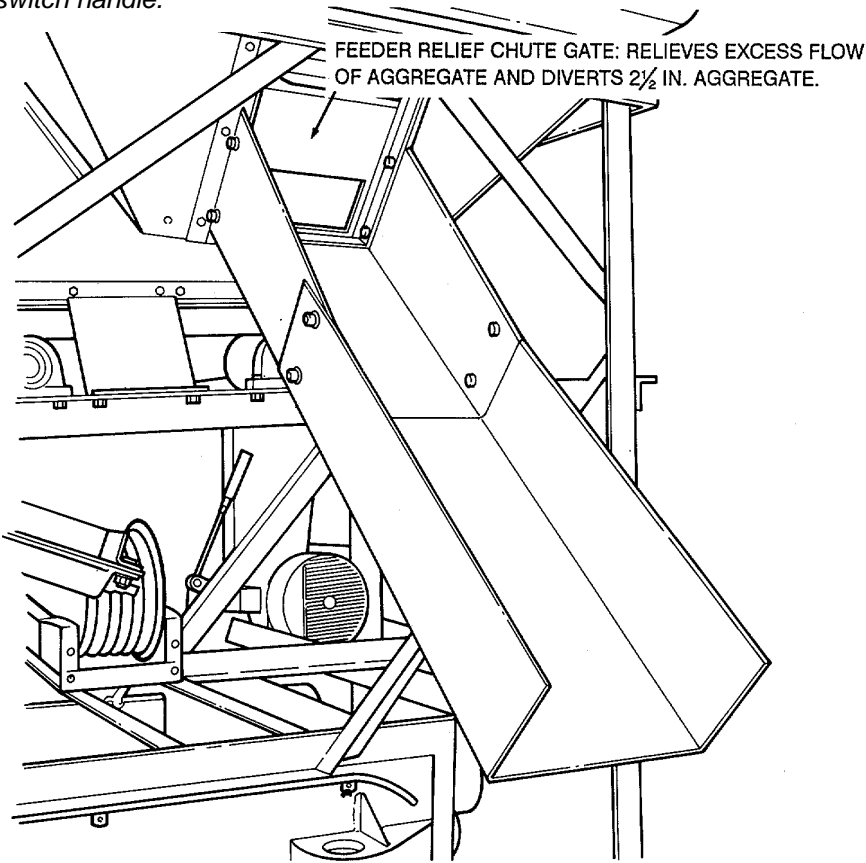
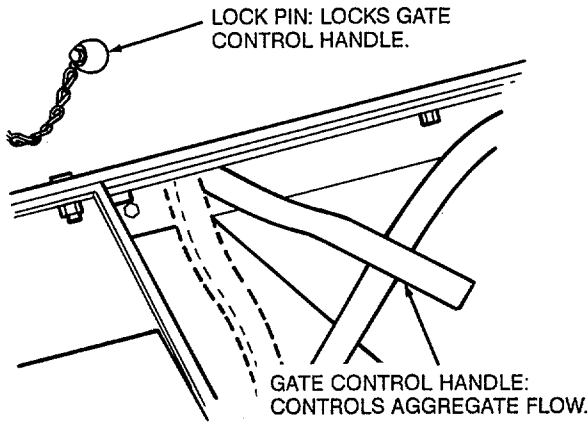

Figure 24. Feeder relief chute gate.



NOTE: FORWARD POSITION OF GATE HANDLE IS FOR AGGREGATE FLOW THROUGH UNDER HOPPER. THE "REAR" POSITION IS FOR AGGREGATE FLOW THROUGH LOWER CHUTE AND UNDER HOPPER.

Figure 25. Discharge control handle.

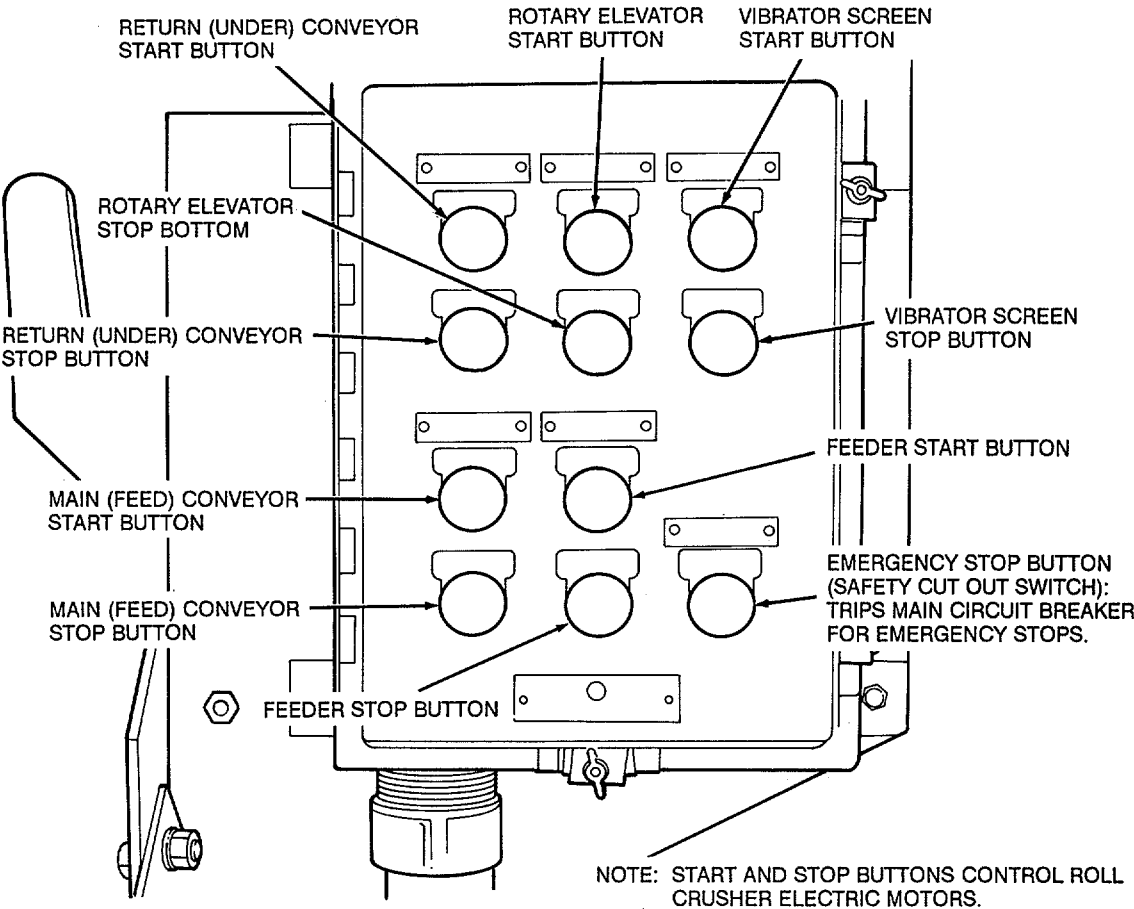
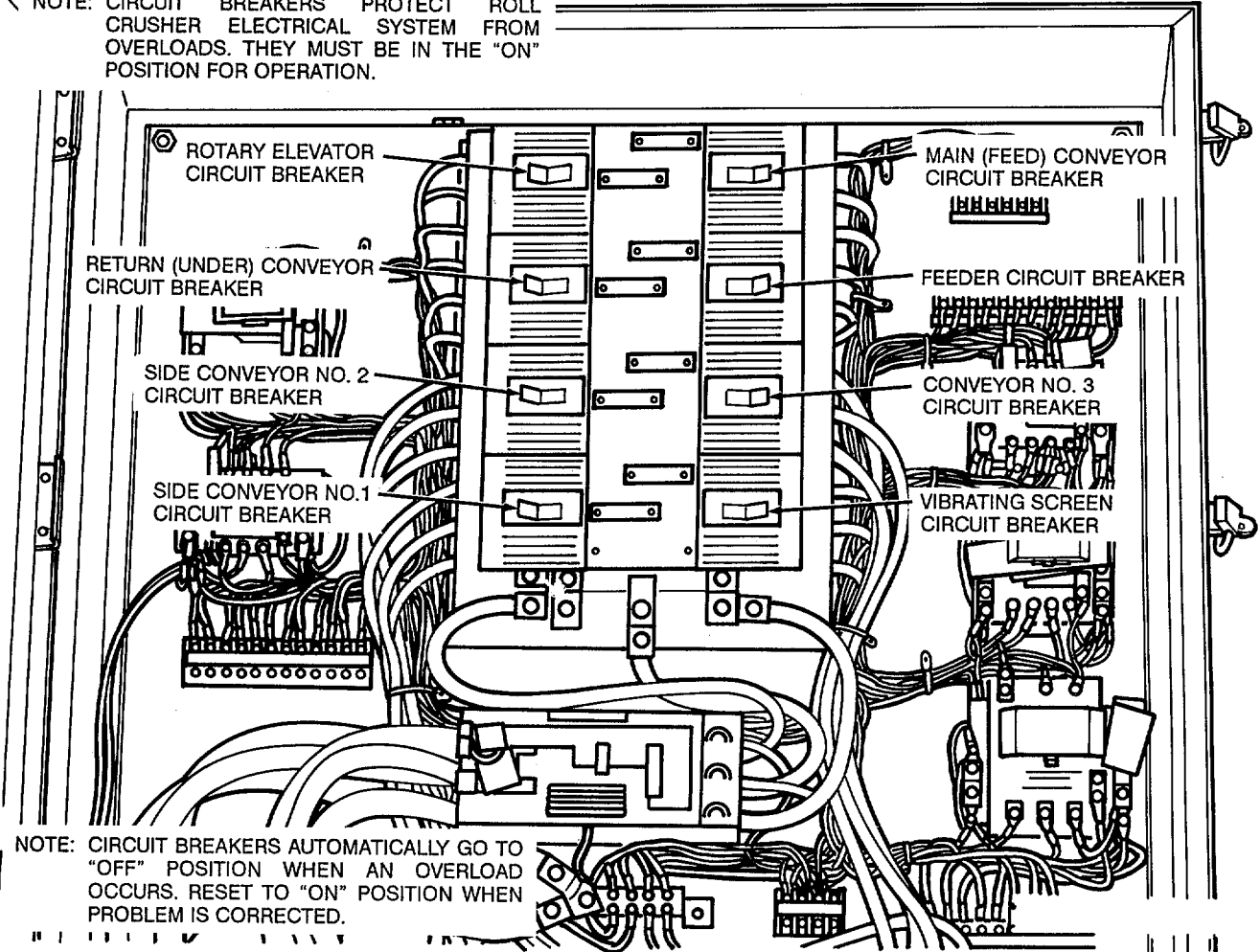

Figure 26. Operator's control panel.

NOTE: CIRCUIT BREAKERS PROTECT ROLL CRUSHER ELECTRICAL SYSTEM FROM OVERLOADS. THEY MUST BE IN THE "ON" POSITION FOR OPERATION.



NOTE: CIRCUIT BREAKERS AUTOMATICALLY GO TO "OFF" POSITION WHEN AN OVERLOAD OCCURS. RESET TO "ON" POSITION WHEN PROBLEM IS CORRECTED.

Figure 27. Main control panel (Model 5230D)

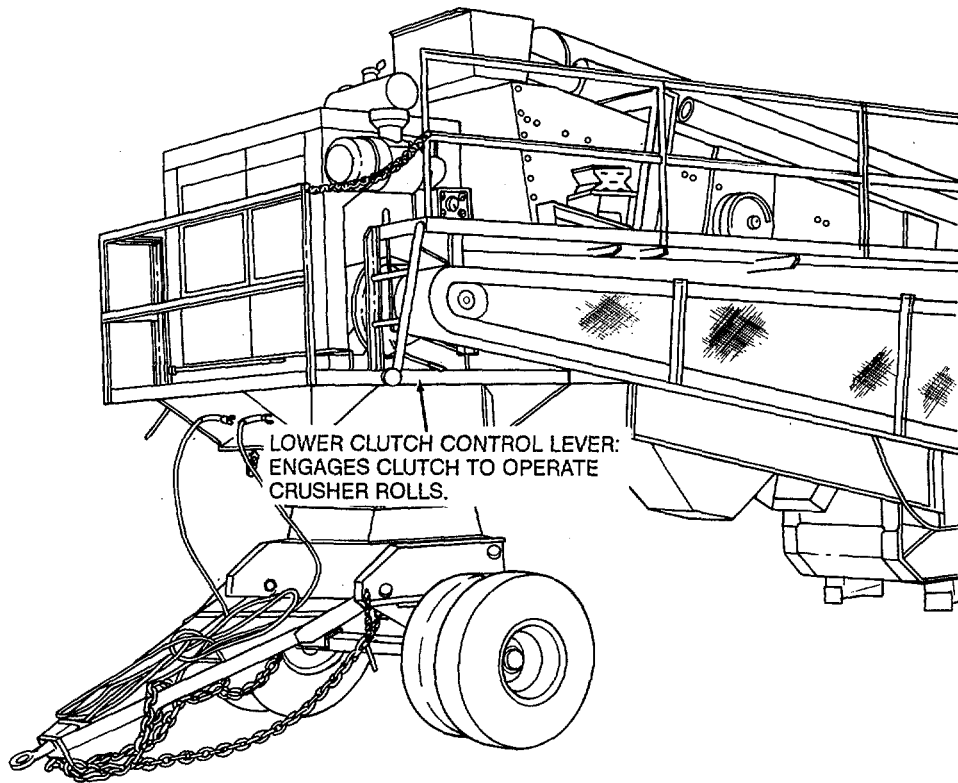

Figure 28. Lower clutch control lever.

Section III. OPERATION OF EQUIPMENT

13. General

- a. The instructions in this section are published for the information and guidance of the personnel responsible for the operation of the roll crusher.
- b. The operator must know how to perform every operation of which the roll crusher is capable. This section provides instructions on starting and stopping the roll crusher, operating the roll crusher, and coordinating the operations to perform the specific tasks for which the roll crusher is designed. Since nearly every job presents a different problem, the operator may have to vary the given procedure to fit the individual job.

14. Starting the Engine

a. Preparation for Starting.

- (1) Perform the Operator/Crew Preventive Maintenance Checks and Services (para 32).
- (2) Open the fuel shut-off valve (fig. 20).

Caution: The manual control fording valve located in. side the fuel tank cap is closed before shipment is made from contractor's plant or depot storage. For proper ventilation of fuel tank, valve must be opened when roll crusher is in operation.

- b. *Starting* Start the engine in the numerical sequence as instructed on figure 29.

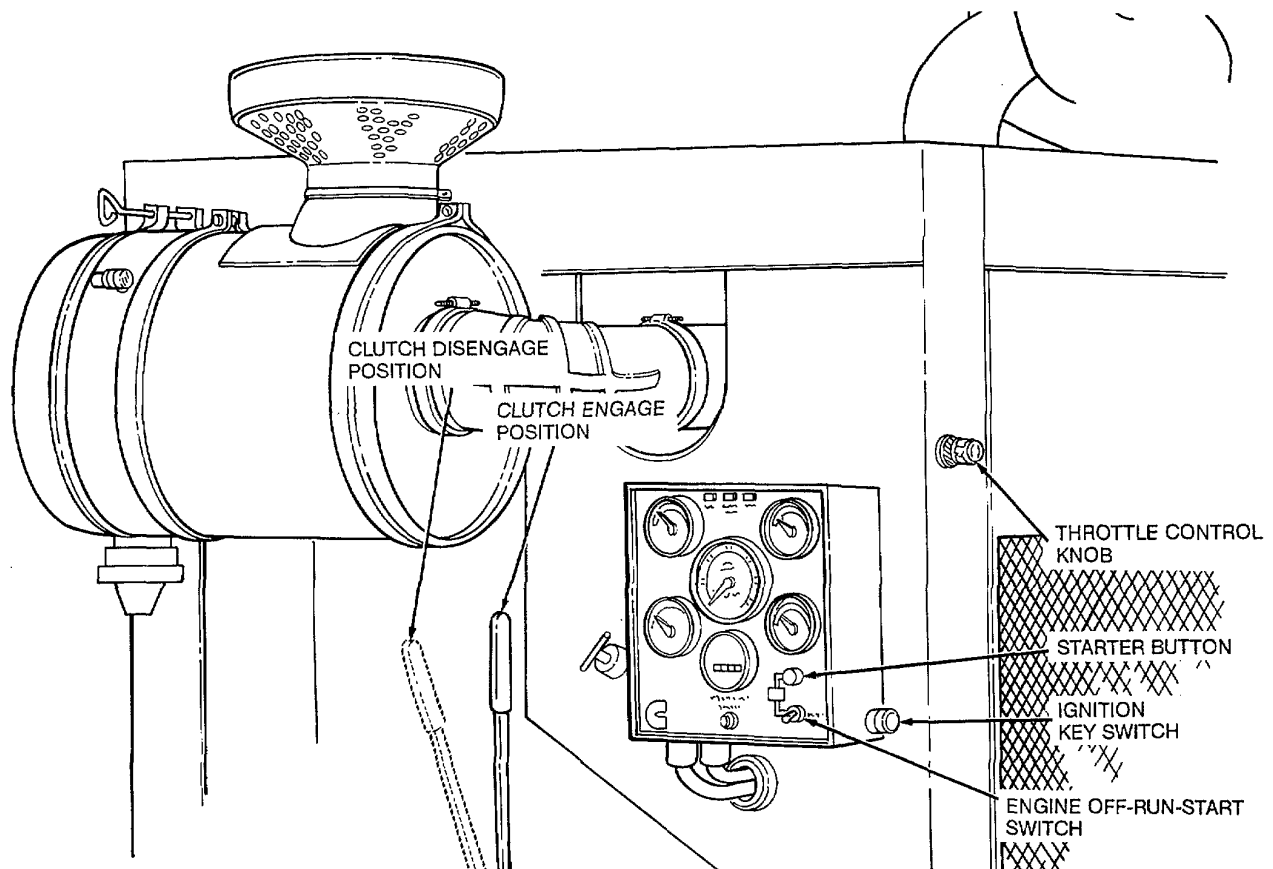

CAUTION: DO NOT CRANK THE ENGINE FOR MORE THAN 30 SECONDS AT A TIME. ALLOW TWO MINUTES BETWEEN ATTEMPTS IF ENGINE FAILS TO START.

- (1) Disengage the clutch and move the throttle knob to idle position (clockwise).
- (2) Turn ignition switch (key switch) to the ON position (clockwise).
- (3) Hold start-run switch in the START (up) position while pressing starter button with the other hand. Immediately release the starter button when the engine starts.
- (4) Continue to hold start-run switch in the START position until oil pressure gage reads above 15 psi, then release switch. Engine should remain running. If not, repeat steps 1-4.

CAUTION: DO NOT RUN THE ENGINE AT CURB IDLE (625 RPM) FOR MORE THAN TEN MINUTES OR ENGINE MAY BE DAMAGED.

- (5) Adjust throttle knob by turning counterclockwise until rpm reads 1000. Allow engine to run (3-5 minutes) until temperature gage reads above 140° F before applying load.
- (6) Observe all instruments and gages for proper operating ranges.

NORMAL READINGS ON GAGES

Engine Coolant Temperature	175°F-195°F
Oil Pressure	Above 35 psi
Oil Temperature	220°F-250°F
Voltmeter	24-28 Volts

- (7) After warm-up, engage clutch and adjust throttle up to the operational speed as marked on the tachometer by paint or tape. The engine rpm should be above 1450 rpm, and not more than 1800 rpm.

Figure 29. Starting the engine.

c. Cold Temperature Starting.

- (1) Follow the procedure outlined in subparagraph a above.

Warning: Starting fluid is highly explosive and toxic. Handle starting fluid spray cans with extreme caution to prevent fire, explosion, and personal injury.

Caution: Do not use excessive amounts of starting fluid when starting the engine. Using too much starting fluid will cause engine damage.

- (2) Start the engine as outlined in subparagraph b above. When pressing the starter button (step 3, fig. 29), spray starting fluid into the air cleaner intake (para 25).

15. Stopping the Engine

Stop the engine in the numerical sequence as instructed on figure 30.

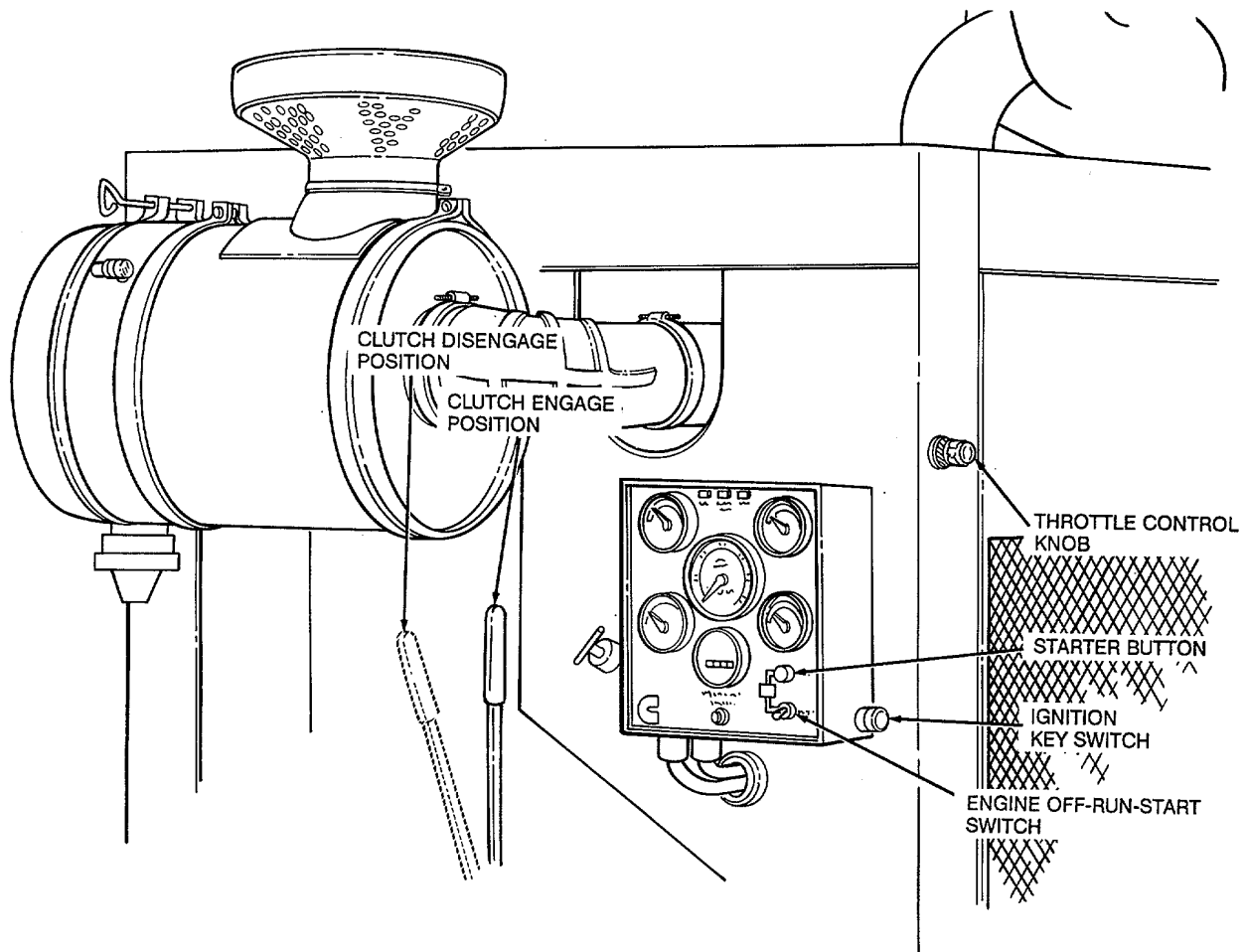

- | | |
|---|---|
| <ol style="list-style-type: none"> (1) Return throttle to idle (625 rpm) by turning throttle knob clockwise (all the way in). (2) Disengage the clutch. <p>CAUTION: DO NOT RUN THE ENGINE AT CURB IDLE (625 RPM) FOR MORE THAN 10 MINUTES OR ENGINE MAY BE DAMAGE.</p> | <ol style="list-style-type: none"> (3) Allow engine to idle for 5 minutes. (4) Move start-run switch to OFF position. (5) Turn ignition key counterclockwise to OFF position. (6) Engage clutch lever to prevent clutch warpage after engine has stopped. |
|---|---|

Figure 30. Stopping the engine.

16. Operating Details

a. *General.* Information given in this paragraph will assist the operator with the operation of the roll crusher in all normal conditions.

b. *Operating the Roll Crusher.*

- (1) Perform the Operator/Crew Preventive Maintenance Checks and Services (para 32).
- (2) Start the engine (para 14).
- (3) Ensure that vibrator screens are of the proper size for the desired grade of aggregate (para 70).

Caution: It is the responsibility of the roll crusher operator to maintain an even distribution of aggregate through the roll crusher and to avoid overloading, jamming, spillage, or other operating practice that could result in damage to the roll crusher components or unsatisfactory production.

- (4) Operate the roll crusher in the numerical sequence as instructed on figures 31-35.
- (5) Engage the clutch as instructed by step 7, figure 29, paragraph 14.

c. *Stopping the Roll Crusher.*

Note: Except for an emergency shutdown, operate the roll crusher until it is empty before shutting down.

- (1) Push stop buttons on motors that are in operation at operator's control panel (fig. 35).
- (2) Move main control switch handle to OFF position (fig. 34).
- (3) Stop the engine (para 15).

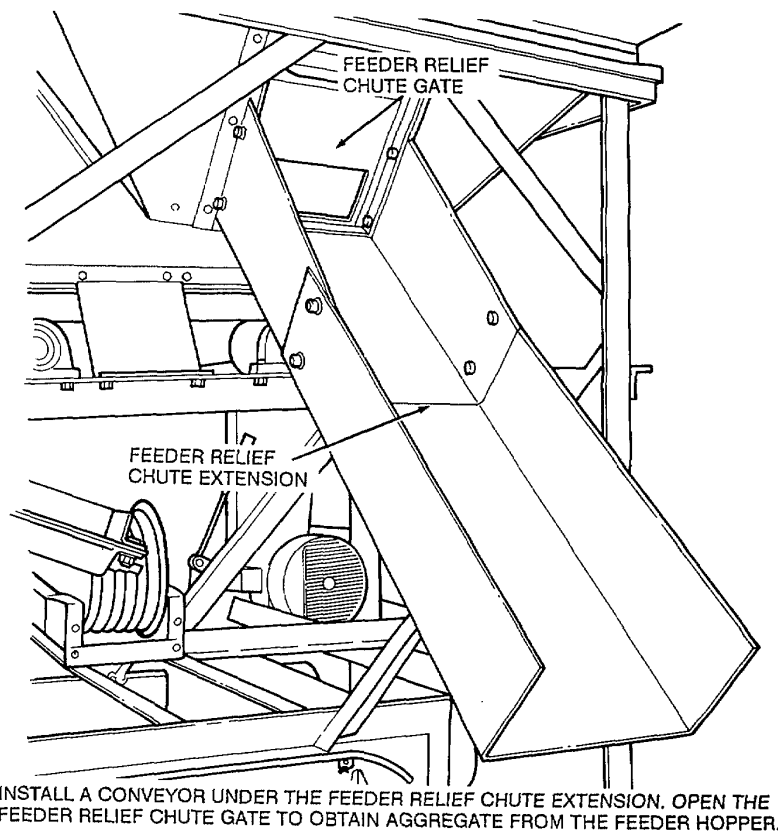
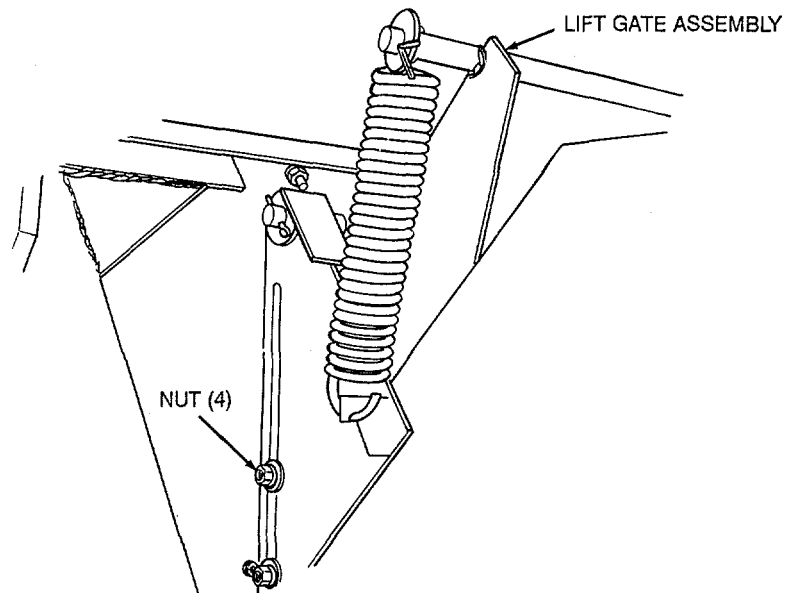
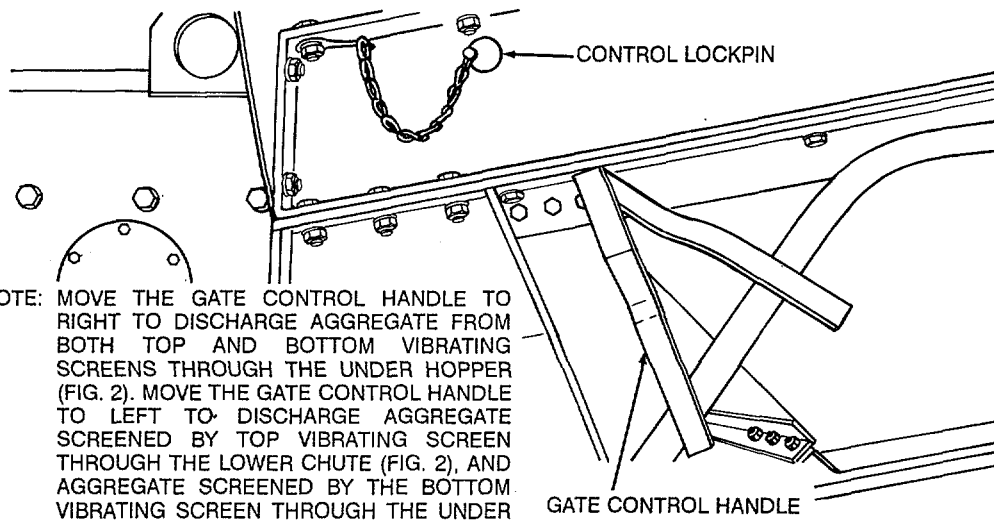

Figure 31. Feeder relief chute operation.



LOOSEN NUT (4). RAISE OR LOWER LIFT GATE ASSEMBLY TO OBTAIN DESIRED AGGREGATE FLOW FROM FEEDER HOPPER. TIGHTEN NUT (4).

Figure 32. Lift gate assembly operation.



NOTE: MOVE THE GATE CONTROL HANDLE TO RIGHT TO DISCHARGE AGGREGATE FROM BOTH TOP AND BOTTOM VIBRATING SCREENS THROUGH THE UNDER HOPPER (FIG. 2). MOVE THE GATE CONTROL HANDLE TO LEFT TO DISCHARGE AGGREGATE SCREENED BY TOP VIBRATING SCREEN THROUGH THE LOWER CHUTE (FIG. 2), AND AGGREGATE SCREENED BY THE BOTTOM VIBRATING SCREEN THROUGH THE UNDER HOPPER (FIG. 2).

REMOVE CONTROL LOCKPIN. MOVE GATE CONTROL HANDLE TO DESIRED POSITION. INSTALL CONTROL LOCKPIN.

Figure 33. Lift gate control handle settings.

NOTE: BEFORE MOVING THE MAIN CONTROL SWITCH HANDLE TO "ON" POSITION, OPEN THE CONTROL PANEL DOOR AND SEE THAT ALL CIRCUIT BREAKERS ARE IN THE "ON" POSITION. CLOSE THE DOOR.

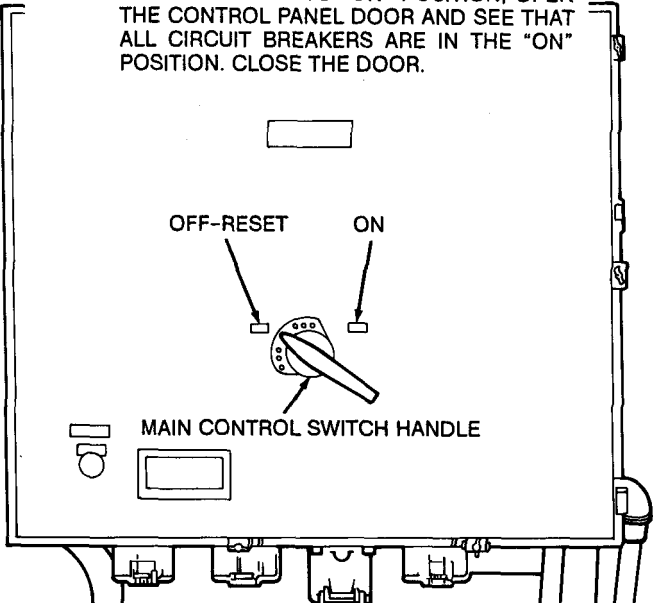
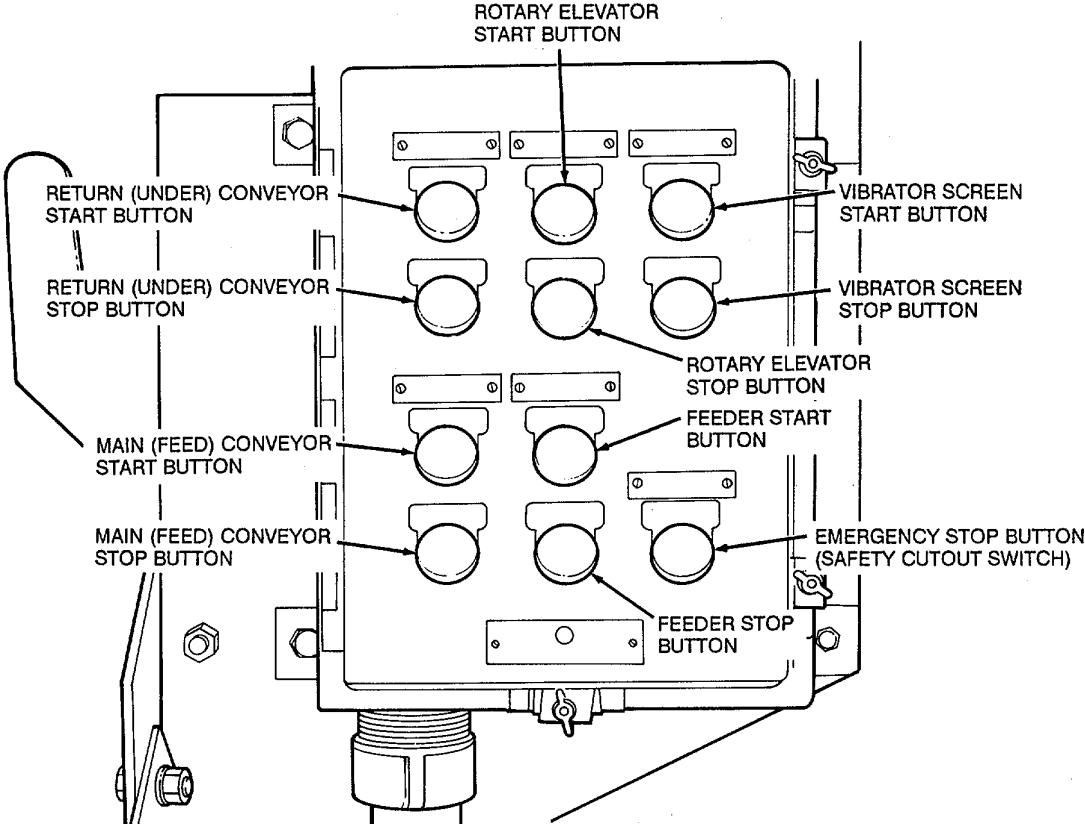

Figure 34. Main control panel switch handle operation.



PUSH START AND STOP BUTTONS TO CONTROL INDIVIDUAL ELECTRIC MOTORS FOR ROLL CRUSHER UNITS. SAFETY CUTOUT SWITCH IS FOR EMERGENCY ONLY.

Figure 35. Operator's control panel operation

17. Operation in Extreme Cold (Below 0°F)

- a. *General.* Special care must be taken when operating the roll crusher in cold weather. Refer to FM 9-207.
- b. *Lubrication.* Use the proper grade of lubricant for all points of lubrication. Refer to LO 5-3820-205-12-1.
- c. *Cooling System.* For checking the antifreeze solution refer to organizational maintenance.

Warning: Do not smoke or allow any flames or sparks in the vicinity while checking or filling the battery. The battery generates hydrogen, a highly explosive gas.

Warning: Battery acid (electrolyte) is extremely dangerous. Serious injury to personnel may result if battery acid contacts skin or eyes.

- d. *Batteries.* A fully charged battery can withstand low temperatures. A partially charged battery may freeze and crack the cells. Keep battery fully charged and the electrolyte at 1/2 in. above the plates (para 61). Refer to TM 9-6140-200-14. If water is added to batteries, run the engine at 1000 rpm for ten minutes.
- e. *Fuel System.* Keep the fuel tank filled to prevent condensation. Any water in the tank will be carried to the fuel filter. Keep the fuel tank cap and vent free from moisture and ice. Drain the wafer from the fuel filter daily during extreme cold weather operation.

18. Operation in Extreme Heat

- a. *Lubrication.* Use the proper grade of lubricant for all points of lubrication. Refer to paragraph 29 and LO 53820-205-12-1 for special lubrication instructions.

Warning: Cooling system is pressurized. Remove radial for cap slowly and only when engine is cool (below 120°F) or painful burns could result.

Caution: Do not add cold coolant to a hot engine or engine may be damaged. Allow engine to cool (below 120°F) before adding coolant.

- b. *Cooling System.* Check the coolant level more frequently and keep the cooling system clean. Avoid the use of water containing alkali, salt, or other substances that would cause rapid formation of scale or rust. Ensure that radiator air passages are clean. If air passages are blocked, or obstructions such as dirt, leaves, or debris cannot be removed by hand, notify organizational maintenance. If engine becomes overheated, allow to cool (below 120°F) before adding coolant, then add coolant in small amounts as the engine is running at idle speed.

Warning: Do not smoke or allow any flames or sparks in the vicinity while checking or filling the battery. The battery generates hydrogen, a highly explosive gas.

Warning: Battery acid (electrolyte) is extremely dangerous. Serious injury to personnel may result if battery acid contacts skin or eyes.

- c. *Batteries.* Water in the batteries will evaporate rapidly at high temperatures. Check the batteries frequently. The electrolyte level should be 1/2 in. above plates. Refer to TM 9-6140-200-14.

19. Operation in Dusty or Sandy Areas

- a. *Lubrication.*

- (1) Clean all filters frequently and clean all lubrication points before applying lubricant.
- (2) Keep the outside of the engine and the electrical motors clean. Dirt left on the outside will eventually filtrate into the motor. Dirt remaining on the outside can also interfere with proper cooling.
- (3) Clean area around the lubrication oil filter cap and dipstick level gage before adding or checking the oil.
- (4) Lubricate in accordance with current lubrication order LO 5-3820-205-12-1.

- b. *Cooling System.*

Warning: Cooling system is pressurized. Remove radial for cap slowly and only when engine is cool (below 120 °F) or painful burns could result.

Caution: Do not add cold coolant to a hot engine or engine may be damaged. Allow engine to cool (below 120°F) before adding coolant.

- (1) Keep the radiator and fins clean and free of foreign material.
- (2) Check the level of coolant in the radiator frequently. Fill to proper level with coolant. Check all hoses and gaskets for leaks.
- (3) Check the air cleaner frequently (para 56).

20. Operation Under Rainy or Humid Conditions

- a. *Lubrication.* Lubricate the roll crusher in accordance with LO 5-3820-205-12-1.

Warning: Cooling system is pressurized. Remove radiator cap slowly and only when engine is cool (below 120°F) or painful burns could result.

Caution: Do not add cold coolant to a hot engine or engine may be damaged. Allow engine to cool (below 120°F) before adding coolant.

b. Cooling System. The transfer of heat from the engine and radiator to the atmosphere is much slower under rainy or humid conditions. To prevent overheating, keep the cooling system full, the radiator cap secure, the radiator core free of obstructions, and the fan belt properly adjusted.

Warning: Do not smoke or allow any flames or sparks in the vicinity while checking or filling the battery. The battery generates hydrogen, a highly explosive gas.

c. Batteries. Keep the outside of the batteries dry and free from corrosion. Clean and coat the terminals and connectors with a suitable grease to prevent corrosion. Check the insulation of the cables and jumpers for signs of deterioration, mold, or mildew.

d. Fuel System. Keep the fuel tank full to prevent condensation. Moisture will accumulate in the air space above the fuel in the tank. Service the fuel filter frequently (para 55).

e. Conveyors and Belts. Keep the scrapers adjusted and belts as clean as possible. Clean the conveyors and belts after each operation to prevent material from drying, caking, and building up on them.

f. Exposed Metal Surfaces. Exposure to high humidity and rain causes rusting and corrosive action on exposed metal surfaces. Coat all unpainted surfaces with a suitable lubrication oil or grease.

g. Protection. Cover the engine, electric motors, and controls with a tarpaulin or similar protection during periods of non-operation. Remove covers and open engine panels to allow unit to dry during dry periods before operation. Paint or coat with grease all exposed metal surfaces to prevent rusting.

21. Operation in Saltwater Areas

a. General. The deterioration and corrosion of exposed metal surfaces is greatly accelerated in saltwater areas. Paint all exposed nonpolished surfaces (TM 43-0139). Coat exposed parts of polished steel and other ferrous materials with standard issue rustproofing material, if available, or cover parts with a light coat of grease. Lubricate the roll crusher in accordance with LO 5-3820-205-12-1.

Warning: Cooling system is pressurized. Remove radial for cap slowly and only when engine is cool (below 120°F) or painful burns could result.

Caution: Do not add cold coolant to a hot engine or engine may be damaged. Allow engine to cool (below 120°F) before adding coolant.

Caution: The cooling system is not intended for use with saltwater. However, saltwater may be used in an emergency. Drain, flush, and fill the cooling system as soon as possible after having used this expedient.

b. Cooling System. Ensure that water used in the cooling system is free of salt or alkali. Use an approved rust inhibitor to prevent the formation of rust or scale in the cooling system.

c. Fuel System. Keep the fuel tank full to prevent accumulation of salt-laden moisture in the tank as a result of condensation of the air in the space above the fuel. Service refuel filter frequently (para 55). Before each operation, open the fuel tank drain valve (para 57) and drain about one pint of fuel from fuel tank. This will normally eliminate any water and dirt that has accumulated in the tank and settled to the bottom while the equipment was idle. Inspect the air cleaner frequently (para 56).

d. Electrical System. Keep the electrical system clean and dry. Wipe the equipment frequently to eliminate moisture and salt deposits. Pay particular attention to electrical terminals, connectors, and switches.

22. Operation in High Altitudes

The roll crusher is designed to operate efficiently at altitudes up to 5000 feet. Above 5000 feet the engine will operate with an increased loss of efficiency as the altitude increases. It is necessary to decrease the amount of fuel injected into the engine to compensate for the lower atmospheric pressure. If the engine is operating erratically, with an apparent loss of power, report this condition to organizational maintenance. Keep the air cleaner and air passages clean and free of obstructions that would restrict the amount of air flowing to the engine.

Section IV. OPERATION OF AUXILIARY MATERIEL USED IN CONJUNCTION WITH THE ROLL CRUSHER

23. Fire Extinguisher (Carbon Dioxide Type)

a Description. ABC fire extinguisher is suitable for use on electrical and flammable liquid fires. The ABC type is of the 5 lb size. The 5 lb extinguisher is portable.

b. Operation. Remove fire extinguisher from its location, break the seal, operate the control valve, and direct the stream at the base of the flame.

c. Refilling and Maintenance. For detailed information on refilling and maintenance, refer to TB 5-4200-200-10.

24. Fire Extinguisher (Dry Chemical Type)

a Description. The dry chemical type fire extinguisher is suitable for use on all types of fires and is effective in areas where ambient temperature is -25°F and above. If winterized (pressured by nitrogen), the fire extinguisher maybe used in temperatures below -25°F . The fire extinguisher is a 2 1/2 lb, stored pressure, lever-operated extinguisher.

b. Operation. Remove the fire extinguisher from its location, lift the handle, and press the lever. Direct the discharge of powder at the base of the flames by using a side-to-side sweeping motion.

c. Refilling and Maintenance. Weigh the fire extinguisher every six months and replace the extinguisher if the weight is less than 4 1/2 lbs, or if the pressure is below 125 lbs. Refer to TB 5-4200-200-10. The dry chemical fire extinguisher will be serviced at installation level through Repair and Utilities facilities, with the filling agent supplied by local procurement through Troop Supply Channels.

25. Cold Weather Starting Aids

Warning: Starting fluid is highly explosive and toxic. Handle starting fluid spray cans with extreme caution to prevent fire, explosion, and personal injury.

Caution: Do not use excessive amounts of starting fluid when starting the engine. Using too much starting fluid will cause engine damage.

Diesel engine starting fluid is used to spray a highly volatile fluid into the air cleaner intake of the engine. The starting fluid helps to ignite the fuel at low ambient temperatures. When the temperature range is $+32^{\circ}\text{F}$ to -25°F use starting fluid (fig. 36).

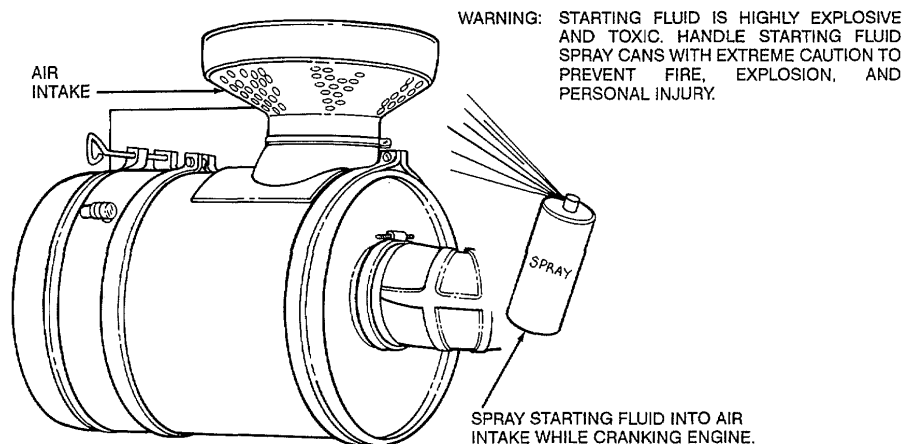

Figure 36. Starting fluid instructions.

CHAPTER 3 MAINTENANCE INSTRUCTIONS

Section I. OPERATOR'S TOOLS AND EQUIPMENT

26. Special Tools and Equipment

There are no special tools or equipment required to perform operator maintenance on the roll crusher.

27. Basic Issue Item Tools and Equipment

The basic issue item tools and equipment authorized for or initially supplied with the roll crusher are listed in Appendix II.

Section II. LUBRICATION

28. General Lubrication Information

- a. This section contains general lubrication instructions and supplemental lubrication instructions which are not specifically covered in the lubrication order.
- b. Refer to LO 5-3820-205-12-1 for specific lubrication instructions.

29. Detailed Lubrication Information

- a. *Care of Lubricants.* When storing or handling lubricants, ensure that the containers are clean and securely covered to prevent dirt, dust, or other foreign matter from entering. Ensure that the lubricant is clean before using it.
- b. *Cleaning.* Clean all surfaces surrounding the point to be lubricated before applying the lubricant. Use a clean cloth dampened in an approved cleaning solvent to clean the surface before lubricating. Remove all excess lubricant after lubrication.
- c. *Points of Application.* The points of application can be located by referring to LO 5-3820-205-12-.

Caution: Over-lubrication may cause equipment failure or damage to working parts.

- d. *Special Lubrication Instructions for Unusual Conditions.* Lubrication intervals will be more frequent when operating the roll crusher during extremely high or low temperature, in dust or sand, or under any condition which tends to destroy the protective quality or quantity of the lubricant.
- e. *Crankcase Breather.* Service the crankcase breather (fig. 37).
- f. *Engine Oil.* When using OEA oil in the crankcase, observe the following precautions:
 - (1) The crankcase oil level must be checked frequently as oil consumption may increase.
 - (2) The oil may require changing more frequently than usual because contamination by dilution and sludge formation will increase under cold weather operating conditions

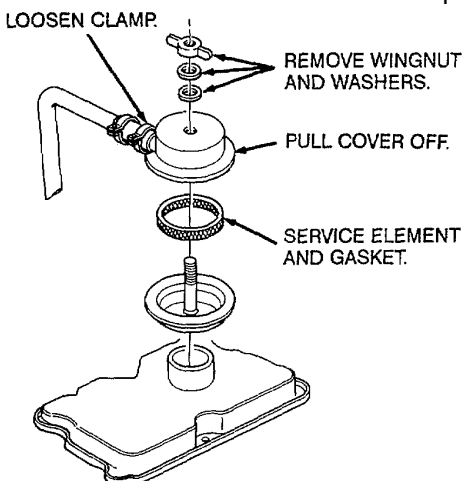

TA507900

Figure 37. Crankcase breather service.

Section III. OPERATOR/CREW PREVENTIVE MAINTENANCE CHECKS AND SERVICES (PMCS)

30. Maintenance Forms and Records

Every mission begins and ends with the paperwork. There isn't much of it, but you have to keep it up. The forms and records you fill out have several uses. They are a permanent record of the services, repairs, and modifications made on your equipment. They are reports to organizational maintenance and to your commander. And they are a checklist for you when you want to know what is wrong with the equipment after its last use, and whether those faults have been fixed. For the information you need on forms and records, refer to DA Pam 738-750.

31. Preventive Maintenance Checks and Services

a. Perform *Before* (B) PMCS just before you operate the equipment. Pay attention to the Cautions and Warnings.

b. Perform *During* (D) PMCS while you operate the equipment, and at halts or rest stops.

c. Perform *After* (A) PMCS right after operating the equipment. Pay attention to the Cautions and Warnings.

d. Perform *Weekly* (W) PMCS once a week.

e. Perform *Monthly* (M) PMCS once a month.

f. If something doesn't work, troubleshoot it with the instructions in this manual or notify your supervisor.

g. Always perform PMCS in the same order so it gets to be a habit. Once you've had some practice, you'll spot anything wrong in a hurry.

h. If anything looks wrong and you can't fix it, write it on your DA Form 2404. If you find something seriously wrong, IMMEDIATELY report it to organizational maintenance.

i. When you perform PMCS, take along the tools you need to make all the checks. You always need a rag or two.

Warning: Dry cleaning solvent, P-D-680, is toxic and flammable. Always wear protective goggles and gloves, and use only in a well-ventilated area. Avoid contact with skin, eyes, and clothes, and DO NOT breathe vapors. DO NOT use near open flame or excessive heat. The solvent's flash point is 100°F-138°F (38°C-59°C). If you become dizzy while using cleaning solvent, immediately get fresh air and medical help. If solvent contacts eyes, immediately wash your eyes and get medical aid.

(1) Keep it clean. Dirt, grease, oil, and debris only get in the way and may cover up a serious problem. Clean as you work and as needed. Use dry cleaning solvent on all metal surfaces. Use soap and water when you clean rubber or plastic material.

(2) Bolts, nuts, and screws. Check them all for obvious looseness, missing, bent, or broken condition. You can't try them all with a tool, but look for chipped paint, bare metal, or rust around bolt heads. If you find one you think is loose, tighten it. If you can't tighten it, report it to organizational maintenance.

(3) Welds. Look for loose or chipped paint, rust, or gaps where parts are welded together. If you find a bad weld, report it to organizational maintenance.

(4) Electric wires and connectors. Look for cracked or broken insulation, bare wires, and loose or broken connectors. Tighten loose connectors and ensure that wires are in good shape.

(5) Hoses and fluid lines. Look for wear, damage, and leaks (wet spots) and ensure that clamps and fittings are tight. A stain around a fitting or connector can mean a leak. If a leak comes from a loose fitting or connector, tighten it. If something is broken or worn out, report it to organizational maintenance.

j. It is necessary for you to know how fluid leakage affects the status of your equipment. The following are definitions of the types/classes of leakage an operator or crew member needs to know to be able to determine the status of his/her equipment. Learn, then be familiar with them and REMEMBER--WHEN IN DOUBT, NOTIFY YOUR SUPERVISOR.

LEAKAGE DEFINITIONS FOR Operator/Crew PCMS

Class I Seepage of fluid (as indicated by wetness or discoloration) not enough to form drops.

Class II Leakage of fluid great enough to form drops, but not enough to cause drops to drip from item being checked/inspected.

Class III Leakage of fluid great enough to form drops that fall from the item being checked/inspected.

Caution: Equipment operation is allowable with minor leakages (Class I or II). Consideration must be given to the fluid capacity in the item/system being checked/inspected. When in doubt, notify your supervisor.

When operating with Class I or II leaks, continue to check fluid levels as required in your PMCS.

Class III leaks should be reported to your supervisor or to organizational maintenance for corrective action.

32. Operator/Crew Preventive Maintenance Checks and Services (PMCS)

B—BEFORE

D—DURING

A—AFTER

W—WEEKLY

M—MONTHLY

ITEM NO.	INTERVAL					ITEM TO BE INSPECTED PROCEDURE: CHECK FOR AND HAVE REPAIRED, FILLED, OR ADJUSTED AS NEEDED	EQUIPMENT IS NOT READY/AVAILABLE IF:
	B	D	A	W	M		
1	•					<p>Note: Perform Weekly (W) as well as Before (B) operation if:</p> <p>1. You are the assigned operator and have not operated the roll crusher since the last weekly.</p> <p>2. You are operating the roll crusher for the first time.</p> <p>EXTERIOR OF EQUIPMENT</p> <p>a. Visually check for fluid leakage or appearance</p> <p>b. Visually check for damaged piping or hoses.</p>	<p>Class III Leaks. of fluid leakage.</p> <p>Broken piping or hoses.</p>
2	•					<p>OPERATOR'S ELECTRICAL CONTROL PANEL</p> <p>Warning: Do not connect electrical power or operate the equipment if the ground connection is not properly installed (fig. 8). Death by electrocution could result from improperly grounded equipment.</p> <p>a. Visually check to see if ground rod is securely mounted and there are no loose connections.</p> <p>b. Check for proper operation. Ensure that switches are in the correct positions and cables are connected (fig. 35).</p>	<p>Roll crusher not grounded.</p>

B—BEFORE

D—DURING

A—AFTER

W—WEEKLY

M—MONTHLY

ITEM NO.	INTERVAL					ITEM TO BE INSPECTED PROCEDURE: CHECK FOR AND HAVE REPAIRED, FILLED, OR ADJUSTED AS NEEDED	EQUIPMENT IS NOT READY/AVAILABLE IF:
	B	D	A	W	M		
3						<p>MAIN ELECTRICAL CONTROL PANEL</p> <p>Warning: Do not connect electrical power or operate the equipment if the ground connection is not properly installed (fig. 8). Death by electrocution could result from improperly grounded equipment.</p> <p>Move main power switch to OFF position, and ensure that all circuit breakers are in the ON position. Check for loose or disconnected cables. Return main power switch to ON position.</p>	<p>Circuit breakers off. Loose or disconnected cables.</p>
4						<p>CONVEYOR BELT AND ASSEMBLIES</p> <p>Check conveyor belt for excessive wear, frayed, or cut condition. Check for broken roller assemblies. Inspect belt fastener assembly.</p>	<p>Broken conveyor belt or roller assemblies. Loose fastener.</p>
5						<p>DRIVE BELTS</p> <p>Visually check for broken or missing drive belts or glazed, shiny surface which indicates drive belt slippage.</p>	<p>Drive belts missing or broken</p>
6						<p>VIBRATING SCREEN</p> <p>Check rubber mountings for tears and cracks.</p>	<p>Rubber mountings torn through or cracked.</p>
7						<p>RECIPROCATING FEEDER</p> <p>Check for cracks, breaks, and freedom of movement.</p>	<p>Cracks or breaks in feeder assembly</p>
8						<p>ROLL CRUSHER ASSEMBLY</p> <p>Check for cracks, breaks, and leftover aggregate. Check tension spring for proper adjustment (para 68). Check gearbox oil before operation and after every ten hours of operation (LO 5-3820 205-20-1).</p>	<p>Roll crusher assembly cracked, twisted, or rock lodged in roller.</p>
9						<p>FIRE EXTINGUISHER</p> <p>Inspect for full charge by checking gage and checking for broken seal.</p>	<p>Gage not reading in green, or seal broken</p>
10						<p>ENGINE CRANKCASE</p> <p>With roll crusher in a level position, check engine oil level and maintain oil level between "L" (low) and "H" (high) marks.</p>	<p>Oil level at or below "L" mark.</p>

B—BEFORE

D—DURING

A—AFTER

W—WEEKLY

M—MONTHLY

ITEM TO BE INSPECTED

ITEM NO.	INTERVAL					PROCEDURE: CHECK FOR AND HAVE REPAIRED, FILLED, OR ADJUSTED AS NEEDED	EQUIPMENT IS NOT READY/AVAILABLE IF:
	B	D	A	W	M		
11		•				<p>ENGINE SAFETY CONTROLS</p> <p>Caution: If the engine starts with less than 15 psi oil pressure, shut off the engine.</p> <p>Note: Ensure that the fuel valve is open.</p> <p>With engine run-start switch in the RUN position press engine start button to engage starter. Engine should not start while engine oil pressure is below 15 psi.</p>	Engine starts wit less than 15 psi oil pressure.
12		•				<p>ENGINE FAN</p> <p>Visually check the fan for cracks, loose rivets, And bent or loose blades</p>	Broken or missing blades.
13					•	<p>AIR CLEANER</p> <p>Warning: If NBC exposure is suspected, all engine air cleaner air filter media should be handled by personnel wearing protective equipment. Consult your NBC Officer or NBC for appropri-ate handling or disposal procedures.</p> <p>Visually check air filter restriction indicator. (Green indicates good condition.)</p>	Air filter restriction indicator is red or element is missing.
14			•		•	<p>INSTRUMENTS AND GAGES</p> <p>a. Oil pressure above 15 psi at 650 rpm. b. Oil temperature normally reads 220°F-250°F Maximum. c. Voltmeter 24-28 volts. d. Tachometer 650 rpm idle to 2100 rpm rated Speed. (Tachometer may stick to rpm at engine shut-down, until engine is restarted.) e. Water temperature 200°F maximum.</p>	Oil pressure below 15 psi. Oil pressure below 15 psi. Voltage not within limits. Tachometer not within limits. Water temperature above 200°F.
15		•				<p>MASTER CLUTCH</p> <p>Check for proper operation and adjustment. Firm pressure is required to engage clutch. If adjustment is needed, report it to organizational maintenance.</p>	Clutch slipping or will not engage.

B—BEFORE

D—DURING

A—AFTER

W—WEEKLY

M—MONTHLY

ITEM NO.	INTERVAL					ITEM TO BE INSPECTED PROCEDURE: CHECK FOR AND HAVE REPAIRED, FILLED, OR ADJUSTED AS NEEDED	EQUIPMENT IS NOT READY/AVAILABLE IF:
	B	D	A	W	M		
16		• •				<p>HOPPERS AND CHUTES</p> <p>a. Check for proper operation. b. Check deflectors for proper adjustment. When hopper is loaded, deflectors should barely touch conveyor belt.</p>	Incorrect deflector adjustment.
17			•			<p>FUEL/WATER SEPARATOR Note: Do not overtighten valve</p> <p>Turn the engine off. Use your hand to open the drain valve. Turn the valve screw counter clockwise about 1/2-2 turns until draining occurs. Drain the filter sump of water until clear fuel is visible, and close fingertight only.</p>	Contaminated fuel visible
18			•			<p>FUEL TANK Note: Do not overtighten valve.</p> <p>Open the drain valve. Drain sediment and Condensation from fuel tank into suitable close the valve fingertight.</p>	Tank or drain valve leaking. (Class III leak only)
19				•		<p>COOLING SYSTEM Warning: Cooling system is pressurized. Remove radiator cap slowly and only when engine is cool (below 120°F) or painful burns could result.</p> <p>Check coolant level. Maintain coolant level to 1 in. from bottom of filler neck. Check shrouds for blocked cracks, breaks, and damage. Check water pump and hoses for leaks. Check radiator to ensure cooling fins are free of mud, dirt, and debris.</p>	Coolant low, any leaks, radiator blocked
20				•		<p>BATTERY Warning: Do not smoke or allow any flames or sparks in the vicinity while checking or filling the battery. The battery generates hydrogen, a highly explosive gas.</p> <p>Warning: Battery acid (electrolyte) is extremely dangerous. Serious injury to personnel may result if battery acid contacts skin or eyes.</p> <p>Check electrolyte level. If level of electrolyte is less than ½ in above plates report it to organizational plates. maintenance.</p>	Electrolyte is less than. ½ in. above plates.

B-BEFORE

D-DURING

A-AFTER

W-WEEKLY

M-MONTHLY

Item NO.	INTERVAL					ITEM TO BE INSPECTED PROCEDURE: CHECK FOR AND HAVE REPAIRED, FILLED, OR ADJUSTED AS NEEDED.	EQUIPMENT IS NOT READY/AVAILABLE IF:
	B	D	A	W	M		
21						CHECKS 21 THROUGH 24 ARE FOR TRANSPORT OF EQUIPMENT TIRES Check for excessive wear, cuts, cracks, abrasions, low or flat tires and proper tire pressure (100 psi), IAW TM 9-2610-200-14.	Air system will not maintain air pressure. Drawbar/dolly cracked or broken. Fifth wheel will not lock.
22						AIRBRAKE SYSTEM Visually check the air lines for cuts, cracks, or broken lines.	
23						DOLLY AND DRAWBAR Visually check for cracks, or broken parts on drawbar and fifth wheel lock area.	
24						AIRBRAKE SYSTEM Drain air tanks after use only.	

Section IV. TROUBLESHOOTING PROCEDURES

33. General

This section provides information useful in diagnosing and correcting unsatisfactory operation or failure of the roll crusher, and its components. Each trouble symptom stated is followed by a list of probable causes of the trouble. The possible remedy recommended is described opposite the probable cause. Any operational trouble beyond the scope of the operator or crew must be reported to organizational maintenance.

34. Engine Hard to Start or Will Not Start (Exhaust Smoke Present)

<i>Probable cause</i>	<i>Possible remedy</i>
Engine cranking speed low (below 150 rpm)	Check engine cranking rpm.
Clutch engaged	Disengage clutch.
Cold start aid needed	Use starting fluid (fig 36).
Fuel filter plugged	Replace fuel filter.
Air in the fuel system	Check for air in fuel. Tighten fuel connections and filter.
Fuel suction line restricted	Check fuel line for restriction.
Intake air system restricted	Check intake air system for restrictions.
Fuel contaminated	Verify by operating engine from a temporary supply tank.

35. Engine Cranks But Will Not Start (No Smoke From Exhaust)

<i>Probable cause</i>	<i>Possible remedy</i>
No fuel in tank	Add fuel.
Fuel tank shut-off valve closed	Open shut-off valve.
No fuel to injectors	Loosen fuel supply line between fuel pump and cylinder head while cranking engine, and check for fuel (fig. 42)

Fuel connections loose on suction side of fuel pump	Tighten all fuel filter fittings and connections from fuel tank to fuel pump.
Fuel filter plugged or suction line restricted	Replace fuel filter. Inspect fuel hose for restriction.
No fuel in pump	Prime fuel pump (fig. 43).
Intake or exhaust restricted	Check intake and exhaust system for restrictions.

36. Engine Starts But Will Not Keep Running

<i>Probable cause</i>	<i>Possible remedy</i>
Air in fuel system	Check for air in fuel, tighten fuel connections and filter.
Clutch engaged	Disengage clutch.
Fuel filter plugged	Replace fuel filter.
Fuel waxing due to cold weather	Check fuel grade.
Fuel suction line restricted	Check fuel line for restriction.
Fuel contaminated	Verify by operating engine from a temporary supply tank.

37. Engine Will Not Shut Off

<i>Probable cause</i>	<i>Possible remedy</i>
Fuel pump shut-off valve disc stuck	Check opening and closing of electrics.
Fuel tank vent plugged or closed	Check manual control fording valve inside fuel cap.
Fuel drain line restricted	Check fuel drain line for loops, crimps, or clamped points.

38. Lubricating Oil Pressure Low

<i>Probable cause</i>	<i>Possible remedy</i>
Incorrect oil level	Check for oil leaks. Add or drain engine oil. Check dipstick calibration.
Oil pressure gage malfunction	Check oil pressure gage. Replace if necessary.
Oil diluted with fuel	Change oil.
Incorrect oil specifications	Change oil and check oil specifications.
Oil filter plugged	Replace oil filter.
Oil temperature above normal	Check coolant temperature for above normal condition (250°F).

39. Coolant Temperature Above Normal

<i>Probable cause</i>	<i>Possible remedy</i>
Low coolant level	Add coolant.
Radiator fins damaged or obstructed with debris	Clean or repair radiator fins.
Collapsed radiator hose	Replace radiator hose.
Loose fan drive or water pump belt	Tighten fan drive or water pump belt.
Incorrect oil level	Add or drain engine oil.
Cooling fan shroud damaged or missing	Repair or replace fan shroud.
Incorrect or malfunctioning radiator cap	Replace radiator cap.
Temperature gage malfunction	Check temperature gage. Replace if necessary.

40. Engine Will Not Reach Rated Speed When Loaded

<i>Probable cause</i>	<i>Possible remedy</i>
Excessive load for engine horsepower rating	Check equipment for proper operation or binding.
Tachometer malfunction	Check rpm with external tachometer.
Throttle linkage adjustment wrong	Check for full throttle travel.
Fuel suction line restricted	Check fuel inlet for restriction.

41. White Smoke or Rough Running at Idle (After Warmup Period)

<i>Probable cause</i>	<i>Possible remedy</i>
Low coolant temperature	Report to organizational maintenance.
Fuel quality poor	Verify by operating engine from a temporary supply tank.

42. Conveyor Does Not Run Properly or Will Not Run

<i>Probable cause</i>	<i>Possible remedy</i>
Too much slack in drive belts	Adjust drive belts (figs. 60-62).
Circuit breaker tripped	Correct cause of overload and reset the circuit breaker.
Grease on drive sheave or belt	Clean grease off drive sheave or belt with approved cleaning solvent.

43. Crusher Rolls Do Not Turn or Come Up To Normal Speed

<i>Probable cause</i>	<i>Possible remedy</i>
Crusher roll drive belts slipping due to dirt or grease on belts and pulleys	Clean crusher roll drive belts and pulleys.
Engine clutch slips	Adjust clutch.

44. Screen Vibrates Excessively

<i>Probable cause</i>	<i>Possible remedy</i>
Loose rubber mounts	Tighten mounting hardware for rubber mounts.
Motor drive belts slipping	Adjust motor drive belts (figs. 51 and 52).

45. Screen Will Not Vibrate

<i>Probable cause</i>	<i>Possible remedy</i>
Drive belts slipping or broken	Adjust V-belts (figs. 51 and 52). Report broken V-belts to organizational maintenance.
Motor circuit breaker or magnetic starter trips	Correct cause of overload or report to organizational maintenance.

46. Feeder Will Not Operate or Works Slowly

<i>Probable cause</i>	<i>Possible remedy</i>
Drive belts slipping or broken	Inspect V-belts for slipping and adjust as required (figs. 57 and 58). Report broken V-belts to organizational maintenance.
Motor circuit breaker or magnetic switch tripped, continues to trip.....	Correct cause of overload or report to organizational maintenance.
Frozen bearing in feeder rollers	Report condition to organizational maintenance.

47. Rotary Elevator Will Not Turn or Turns at Low Speed

<i>Probable cause</i>	<i>Possible remedy</i>
Drive belts slipping	Adjust drive belts (fig. 59).
Circuit breaker tripped	Correct cause of overload and reset circuit breaker.

48. Electric Motors Will Not Run

<i>Probable cause</i>	<i>Possible remedy</i>
Circuit breaker or relay overload tripped	Reset circuit breaker or relay overload (figs. 17 and 18).
Voltage source fluctuating	Report condition to organizational maintenance.

49. Electric Motors Run Too Hot

<i>Probable cause</i>	<i>Possible remedy</i>
Motors overloaded	Check condition of machinery driven by motor. Correct deficiencies or report to organizational maintenance.
Trash or foreign matter obstructing air flow through motors.....	Remove any obstruction blocking air flow through motors.
Defective motor	Report defective motor to organizational maintenance.
Voltage source fluctuating	Check power source for proper voltage.

Section V. FIELD EXPEDIENT REPAIRS

50. General

Upon decision of the unit commander during emergencies, the following expedient repairs may be used to temporarily correct operational troubles in the field where supplies and repair parts for normal corrective maintenance are not available. Equipment so repaired must be removed from operation as soon as possible and properly repaired before being placed in operation again.

51. Engine Overheats or Runs Cold

<i>Trouble</i>	<i>Expedient remedy</i>
----------------	-------------------------

Coolant thermostat defective	Remove thermostat and run engine until replacement is available.
------------------------------------	--

52. Loss of Lubricating Oil

<i>Trouble</i>	<i>Expedient remedy</i>
----------------	-------------------------

Small hole in crankcase oil pan	Plug hole with wooden plug or metal screw.
Damaged oil line	Tape or wrap oil line with a suitable material until a new oil line can be installed.

53. Loss of Fuel

<i>Trouble</i>	<i>Expedient remedy</i>
----------------	-------------------------

Hole in fuel tank	Plug hole with wooden plug or metal screw.
Fuel line damaged	Tape or wrap fuel line with a suitable material until new fuel line can be installed.

Section VI. FUEL SYSTEM

54. General

The engine fuel system consists of a 100 gal. fuel tank, fuel lines and fittings, fuel filter, fuel injection pump, and six fuel injectors.

55. Fuel Filter

The fuel filter is a fuel-water separator type of filter. Service the fuel filter daily as follows: Shut off the engine. Use your hand to open the drain valve. Turn the valve counterclockwise about 1/2-2 turns until draining occurs. Drain the filter sump of water until clear fuel is visible(fig. 38). Turn the valve clockwise to close the drain valve.

CAUTION: MECHANICAL OVERTIGHTENING CAN DISTORT THE THREADS OR DAMAGE THE FILTER ELEMENT SEAL.

CHANGE FILTER. CLEAN AREA AROUND FUEL FILTER HEAD. REMOVE FILTER, AND CLEAN GASKET SURFACE OF FILTER HEAD. USE CLEAN OIL TO LUBRICATE THE FILTER SEAL, AND FILL NEW FILTER WITH CLEAN FUEL. INSTALL PER INSTRUCTIONS ON FUEL FILTER.

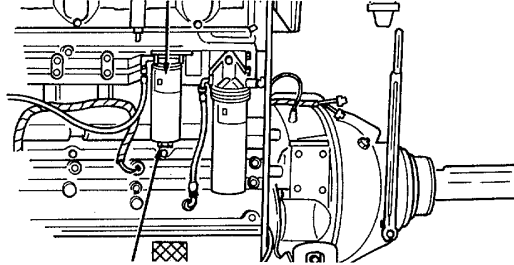

CAUTION: DO NOT OVERTIGHTEN THE VALVE, OR THREADS WILL BE DAMAGED.

DRAIN WATER FROM FILTER. SHUT OFF ENGINE. TURN VALVE COUNTERCLOCKWISE 1/2 TO 2 TURNS UNTIL DRAINING OCCURS. DRAIN UNTIL CLEAR FUEL IS VISIBLE.

Figure 38. Fuel filter service

56. Air Cleaner

Warning: If NBC exposure is suspected, all engine air cleaner air filter media should be handled by personnel wearing protective equipment. Consult your NBC Officer or NBC for appropriate handling or disposal procedures.

Visually check the air filter restriction indicator, normally green for correct filter condition (fig. 39). If indicator flag is red, or element is missing, report it to organizational maintenance.

57. Fuel Tank, Strainer, Lines and Fittings

Inspect the fuel tank, lines and fittings for damage or leaks. Service the fuel tank by cleaning around the fuel cap and fuel gage. Drain sediment and wafer from the bottom of the fuel tank by opening the drain valve (fig. 40). Clean the fuel strainer; if damaged, report it to organizational maintenance.

RED SIGNAL INDICATES FILTER ELEMENT SERVICE IS REQUIRED. REPLACE THE FILTER ELEMENT, AND PRESS THE RUBBER RESET BUTTON ON TOP OF THE INDICATOR.

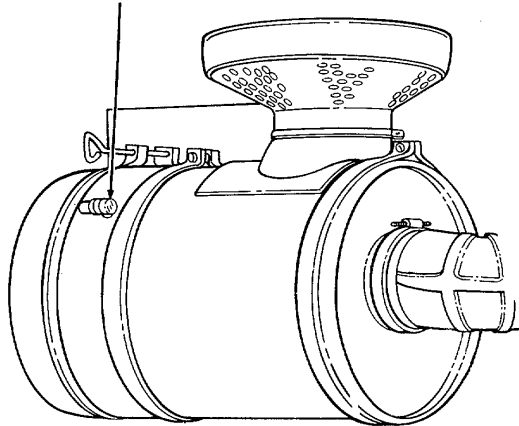
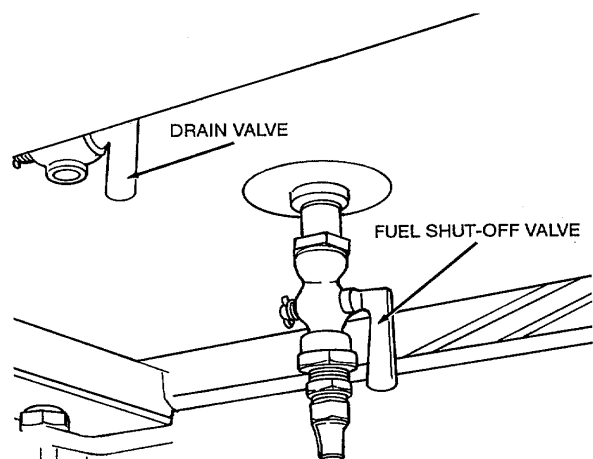

Figure 39. Air filter restriction indicator.



NOTE: OPEN DRAIN VALVE AND DRAIN FUEL SEDIMENT AND CONDENSATION INTO A SUITABLE CONTAINER.

Figure 40. Draining fuel tank

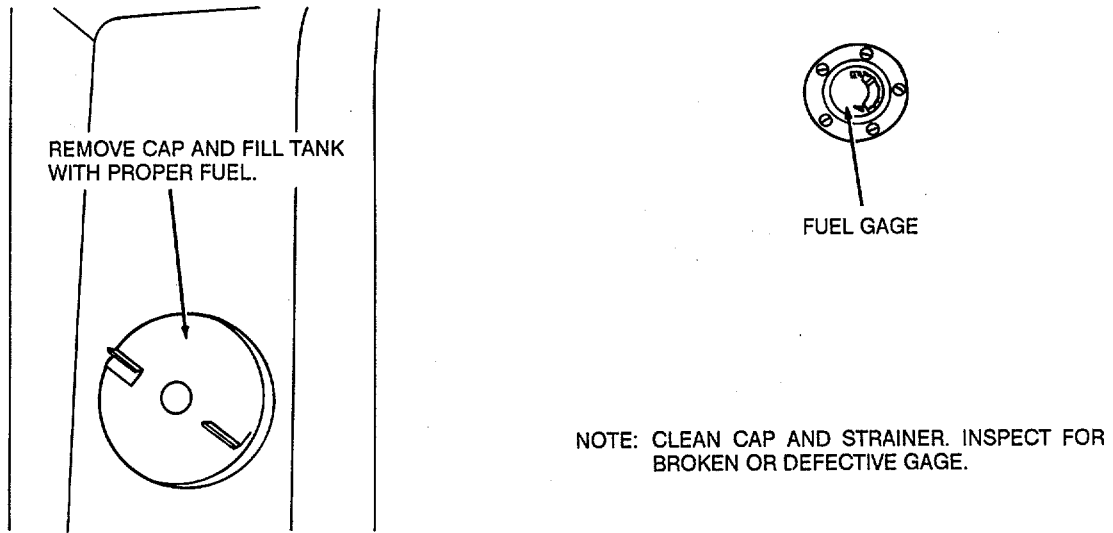

Figure 41. Filling fuel tank and strainer service.

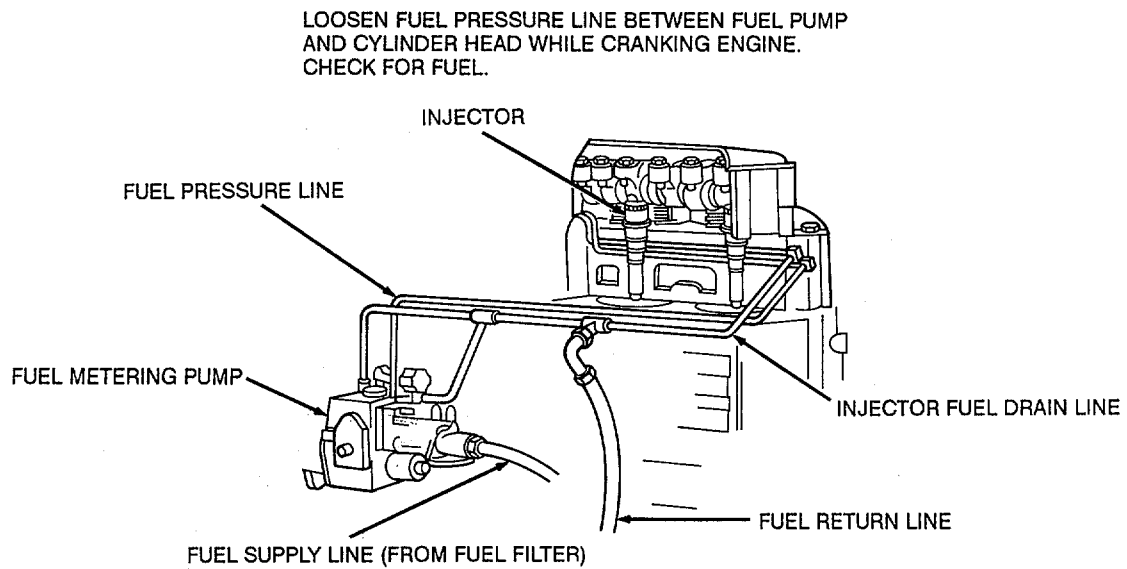

Figure 42. Checking fuel flow to injectors.

CAUTION: CLEAN OUTSIDE OF FUEL PUMP BEFORE PRIMING.

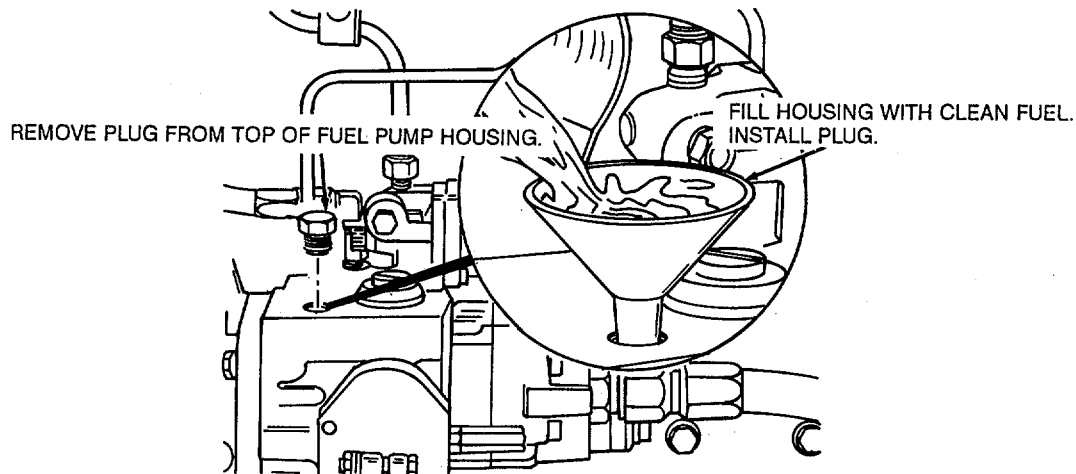

Figure 43. Priming the fuel pump.

Section VII. COOLING SYSTEM

58. General

The liquid cooling system consists of the radiator, hoses, lines, fittings, water pump, fan and coolant passages in the cylinder head and block. The coolant temperature is regulated from 175°F-195°F by a thermostat located inside the thermostat housing.

59. Radiator, Hoses, Lines, Fittings, Water Pump, Fan and Belts

a. Inspect the radiator for leakage or damaged cooling fins. Make sure the air passages are clean. If air passages are blocked, or obstructions such as dirt, leaves, or debris cannot be removed by hand, notify organizational maintenance.

Warning: Cooling system is pressurized. Remove radiator cap slowly and only when engine is cool (below 120°F) or painful burns could result.

Caution: Do not add cold coolant to a hot engine or engine may be damaged. Allow engine to cool (below 120 °F) before adding coolant.

b. Check coolant level in radiator. Coolant should be 1 in. from bottom of filler neck (fig. 44).

c. Inspect the cooling system hoses and hose connections for leaks or deterioration. Particles of deteriorated hose can be carried through the cooling system and slow or partially stop circulation.

d. Inspect water pump for drive pulley wobble, and grease or water leakage around the water pump shaft.

Warning: Never pull or pry on the fan. This can damage the fan blade and cause fan failure, resulting in damage to equipment and serious injury to personnel.

e. Inspect the cooling fan for cracks, loose rivets, and bent or loose blades. Check the fan to make sure it is securely mounted. Check the fan hub for wobble and grease leakage.

f. Inspect fan belts for cracks or frays. Belts that have a glazed or shiny surface indicate belt slippage. Belts correctly installed and tensioned will show even pulley and belt wear.

g. Inspect thermostat housing and water manifold for leaks or loose connections.

WARNING: COOLING SYSTEM IS PRESSURIZED. REMOVE CAP SLOWLY AND ONLY WHEN ENGINE IS COOL (BELOW 120°F). PAINFUL BURNS COULD RESULT.

CAUTION: DO NOT ADD COLD COOLANT TO A HOT ENGINE. ALLOW ENGINE TO COOL (BELOW 120°F), THEN ADD COOLANT IN SMALL AMOUNTS AS THE ENGINE RUNS AT IDLE SPEED.

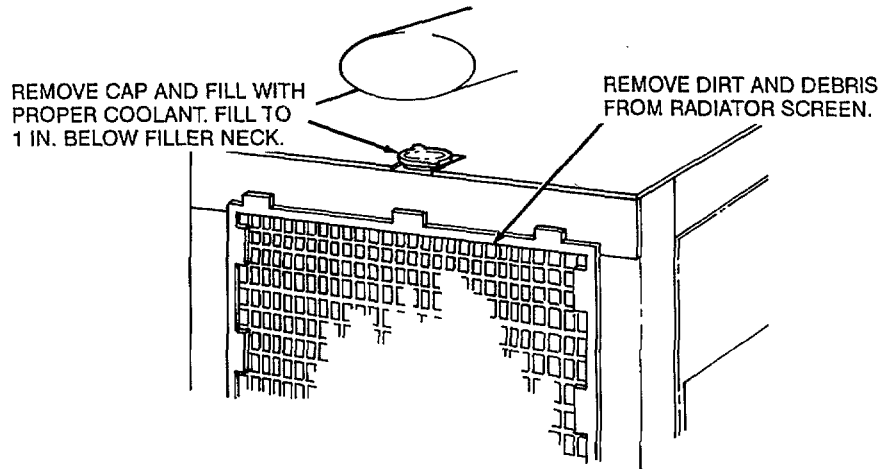

Figure 44. Radiator service

Section VIII. ENGINE ELECTRICAL SYSTEM

60. General

The engine electrical system consists of the generator, generator regulator, four 12 volt batteries, engine safety controls, and the control/indicator panel. The batteries are connected in series-parallel to provide 24 volts for the engine electrical system. The electrical system has a negative ground.

61. Batteries

Warning: Do not smoke or allow any flames or sparks in the vicinity while checking or filling the battery. The battery generates hydrogen, a highly explosive gas.

Warning: Battery acid (electrolyte) is extremely dangerous. Serious injury may result if battery acid contacts skin or eyes.

- a. Inspect the batteries for corrosion, cracks' leaks, or damaged vent caps. Check for loose battery cables by hand. Remove vent caps and make sure the electrolyte level is f. in. above the plates (figs. 45-47).
- b. Check engine safety controls. For a functional check of the safety controls, refer to item 11 of the Operator/ Crew PMCS.
- c. Inspect engine control/indicator panel for broken gages, switches, and burned out light bulbs.

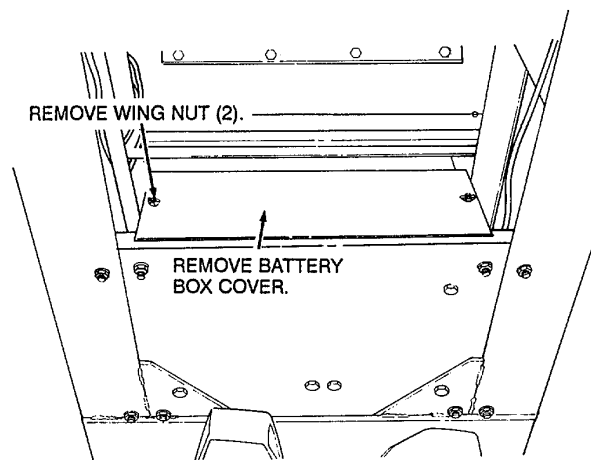
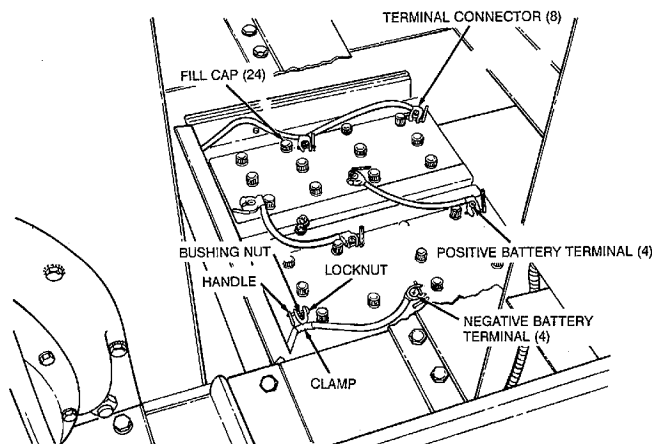
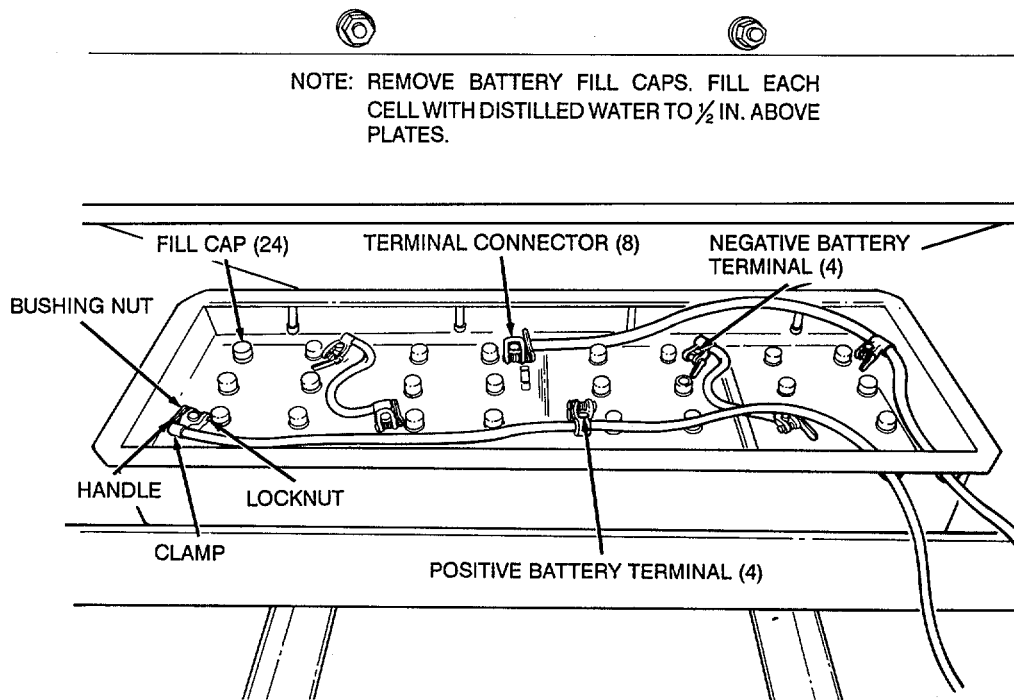

Figure 45. Battery box.



NOTE: REMOVE BATTERY FILL CAPS. FILL EACH CELL WITH DISTILLED WATER TO 1/2 IN. ABOVE PLATES.

Figure 46. Batteries service.



Section IX. AIRBRAKE SYSTEM

62. General

The airbrake system has two filters to remove moisture and foreign matter from the system, and an air tank for an emergency supply of air.

63. Airbrake System

- a. Inspect air lines for cuts, cracks, or broken lines.
- b. Service the air filters (fig. 48).

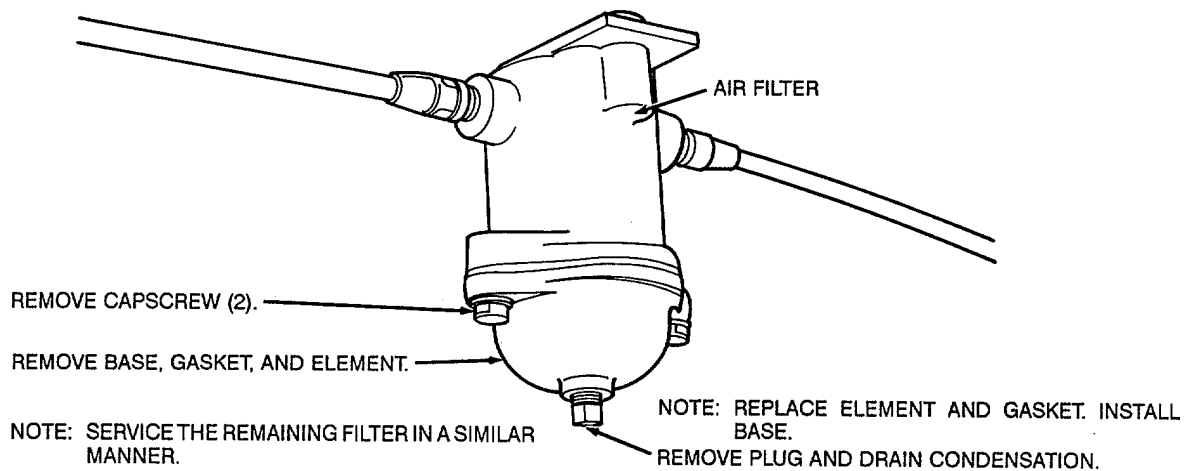

- c. Service the air reservoir (fig. 49).

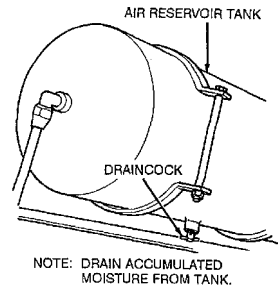

Figure 49. Air system reservoir service.

Section X. EXHAUST SYSTEM

64. General

The exhaust system consists of a exhaust silencer and exhaust pipe.

65. Inspection

Inspect the exhaust silencer and exhaust pipe for cracks or holes. Check for loose exhaust silencer clamps. Ensure that there are no restrictions in the exhaust silencer or exhaust pipe (i.e., rust, debris).

Section XI. ENGINE CLUTCH ASSEMBLY

66. General

The engine clutch assembly engages and disengages the power from the diesel engine to the crusher roll drive belts.

67. Engine Clutch Assembly

a. Inspect the engine clutch assembly for cracks and loose bolts or engagement handles. The clutch should engage within four seconds (with engine running). Adjustment may be required if engagement takes longer. If adjustment is required, notify organizational maintenance.

b. Service the clutch by following the lubrication instructions on the data plate located at the top of the clutch

SECTION XII. ROLL CRUSHER ASSEMBLY

68. General

The crusher rolls must be adjusted when the screens are replaced to obtain the desired grade of aggregate. The roll crusher assembly consists of a smooth roll and a grooved roll for crushing stone. It has a spring on each side to allow the smooth roll to move beyond its adjusted clearance to allow tramp iron and other items to pass through the rolls that would otherwise damage the crusher rolls. An adjusting screw, located on each side to adjust the clearance between the crusher rolls, aids in obtaining the desired grade of aggregate.

69. Crusher Rolls Adjustment

Note: In making a roll adjustment the sealing surface for the O-rings will be changed. In some cases it may require several hours of operation before the O-rings seat properly against the seal plate and the oil stops leaking. A leak of 2-3 qts of oil in eight hours is not considered excessive (gearcase capacity is 92 qt) as compared to the cost of replacing the O-rings. Furthermore, the O-rings are not designed as a positive type seal but are designed to allow seepage which will lubricate the Wrings and prevent dust from entering the gearcase. The oil level of the gearcase should be checked each day. Refer to LO 5-3820-205-12-1.

Adjust the crusher rolls in the numerical sequence as instructed on figure 50.

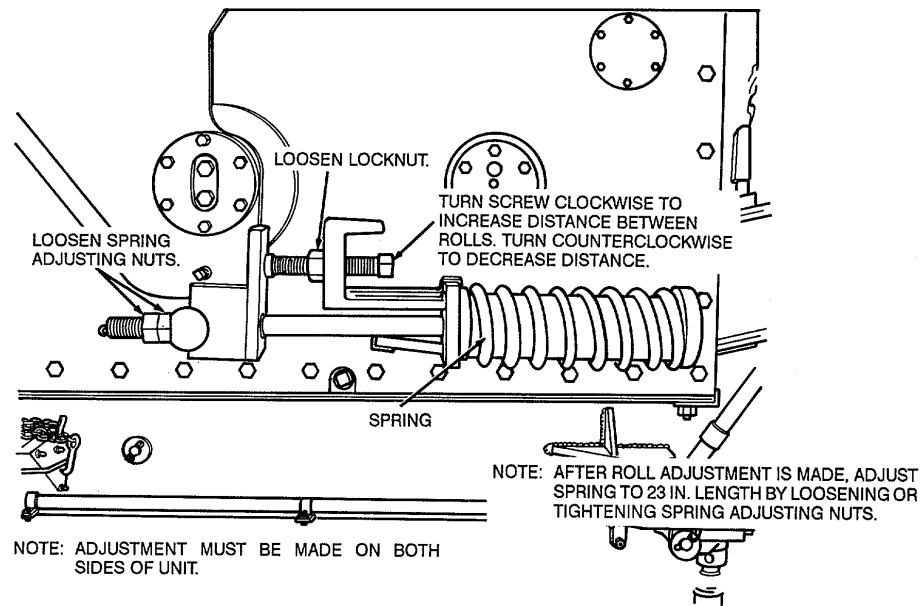

Figure 50. Crusher rolls, adjustment.

SECTION XIII. VIBRATING SCREEN ASSEMBLY

70. General

The vibrating screen is driven by an electric motor. Power is transmitted to the vibrating screen, from the electric motor, by two V-belts. The vibrator screens determine the grades of aggregate desired. When the vibrator screens are changed, the crusher roll clearance must be adjusted (fig. 50) to the size of the largest screen opening used.

71. Vibrating Screen Drive Belts Adjustment

Adjust the vibrating screen drive belts (figs. 51 and 52).

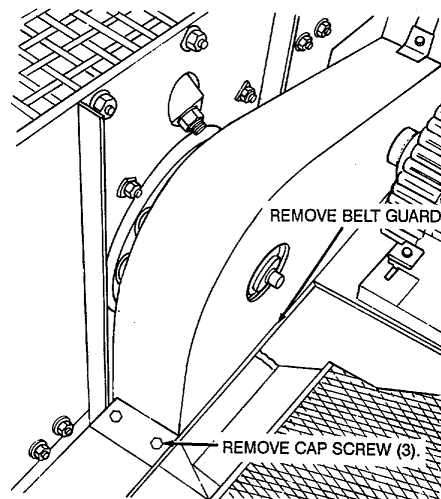

Figure 51. Vibrating screen drive belt guard removal.

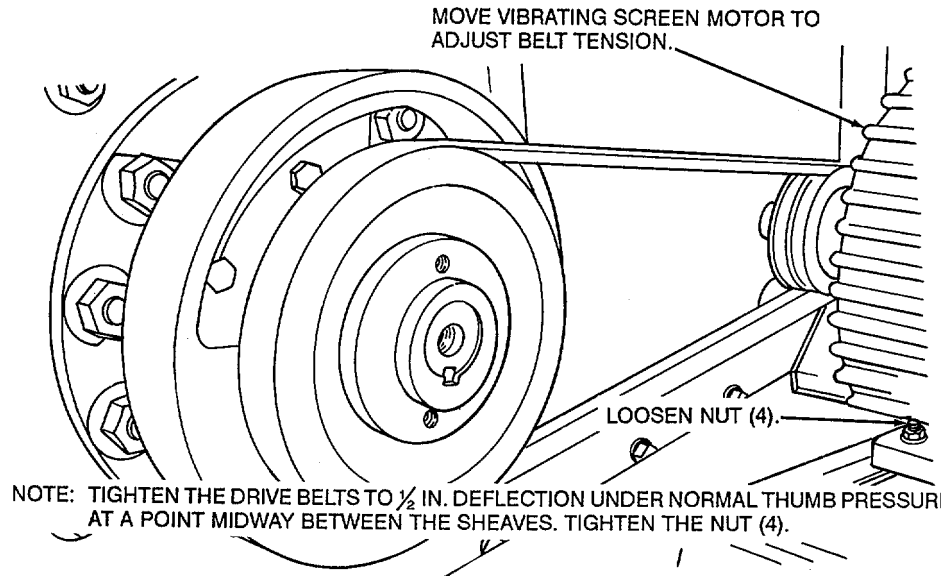

Figure 52. Vibrating screen drive belts, adjustment.

72. Vibrating Screens Replacement

Note: Exhaust silencer and lower vibrating screen access and plate removal is only necessary when lower screen is to be removed.

Replace the vibrating screens with the proper sized screens to obtain the desired grades of aggregate in the numerical sequence as instructed on figures 53 through 56.

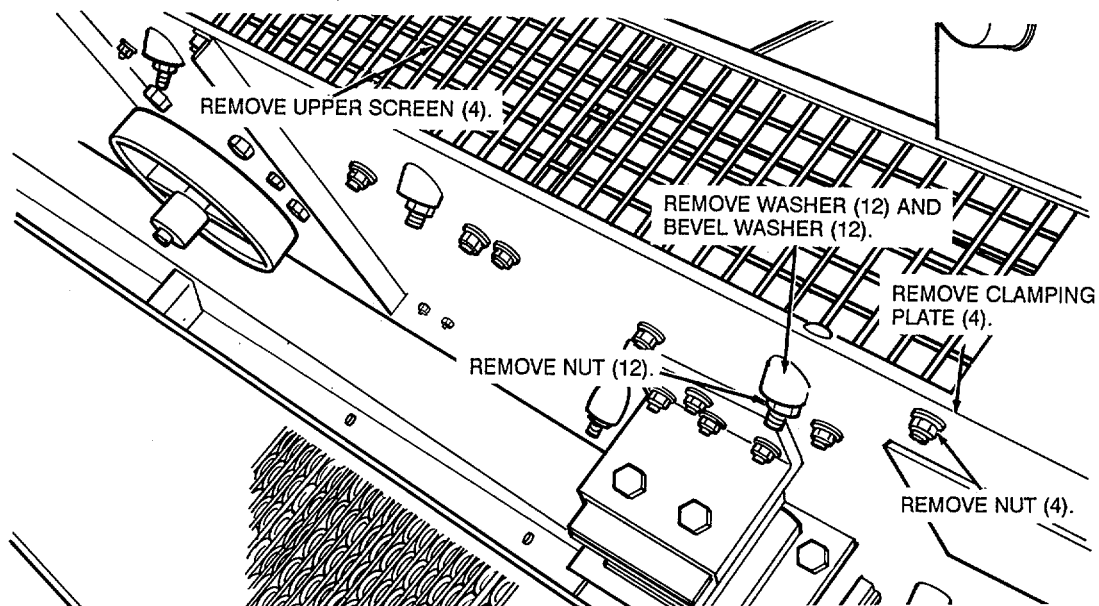

Figure 53. Upper vibrating screen replacement.

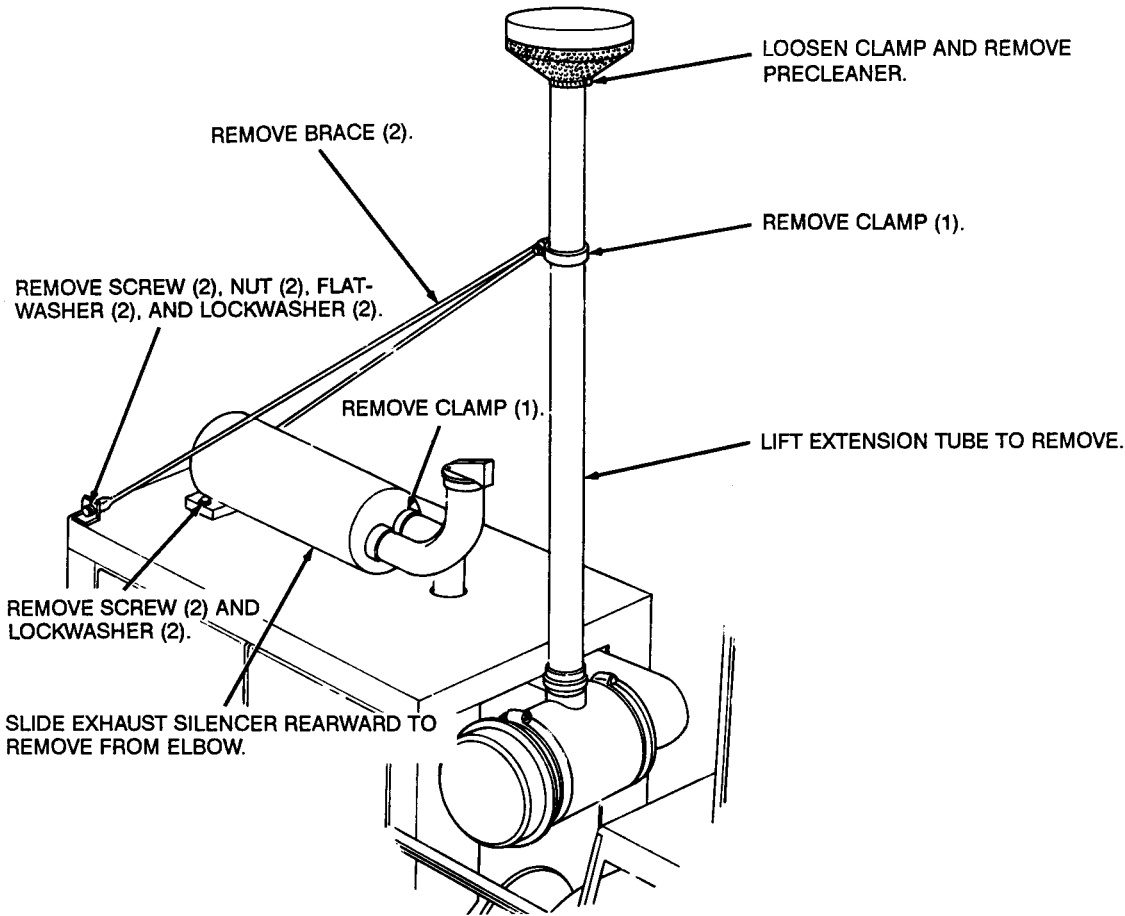

Figure 54. Air intake extension tube and precleaner, and exhaust silencer removal and installation.

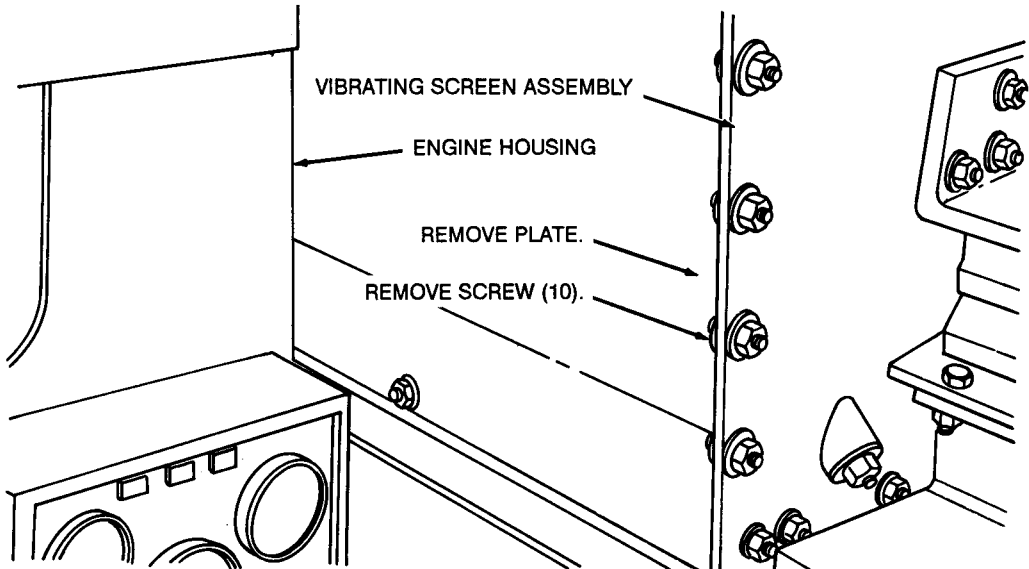

Figure 55. Lower vibrating screen access plate removal.

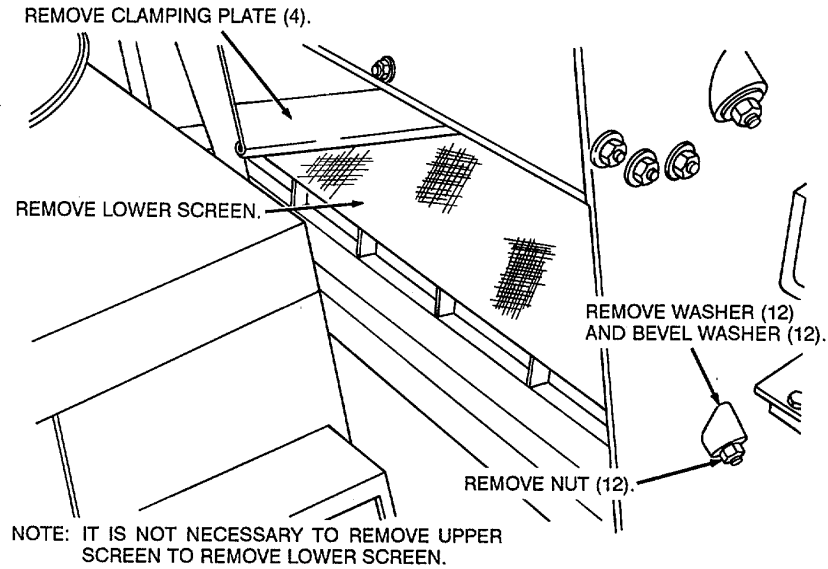

Figure 56. Lower vibrating screen replacement.

SECTION XIV. FEEDER ASSEMBLY

73. General

The feeder assembly feeder pan is driven by an electric motor. Power is transmitted from the electric motor to the feeder by two V-belts.

74. Feeder Drive Belts Adjustment

Adjust the feeder drive belts (figs. 57 and 58).

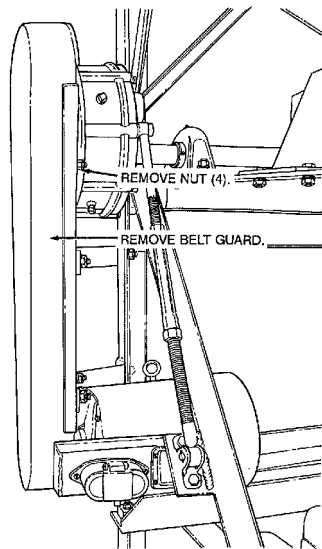

Figure 57. Feeder drive belt guard removal.

TA507911

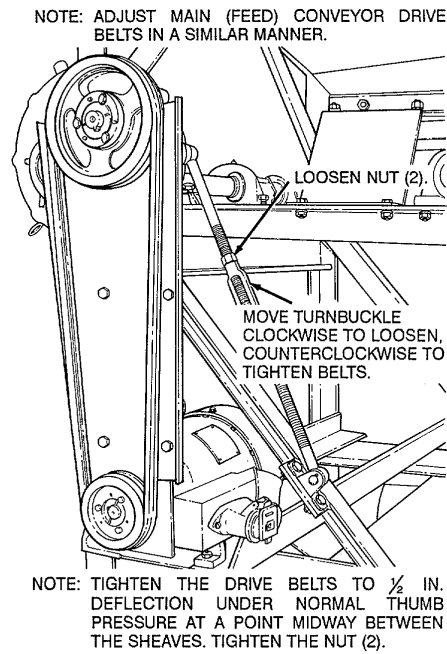

Figure 58. Feeder drive belts, adjustment.

SECTION XV. ROTARY ELEVATOR ASSEMBLY

75. General

The rotary elevator is used to hoist the aggregate being discharged by the return conveyor onto the main conveyor. It is driven by an electric motor. Power is transmitted from the electric motor to the rotary elevator by two V-belts.

76. Rotary Elevator Drive Belts Adjustment

- Remove the belt guard on the rotary elevator in the same manner as the feeder belt guard (fig. 57).
- Adjust the rotary elevator drive belts (fig. 59).
- Install the rotary elevator drive belt guard in the same manner as the feeder drive belt guard (fig. 57).

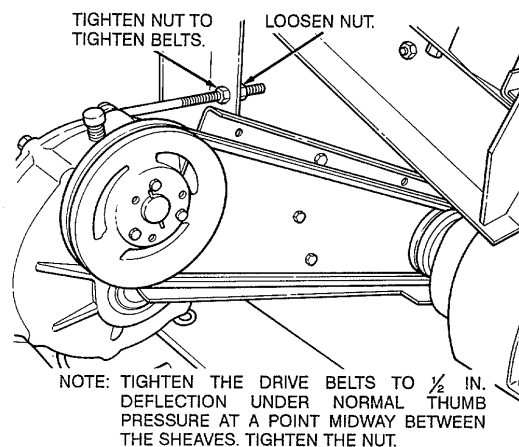

Figure 59. Rotary elevator drive belts, adjustments.

SECTION XVI. RETURN (UNDER) CONVEYOR ASSEMBLY

77. General

The return (under) conveyor assembly conveys aggregate being discharged by the crusher rolls into the roll elevator. It is driven by an electric motor. Power is transmitted from the electric motor to the return (under) conveyor by two V-belts.

78. Return (Under) Conveyor Drive Belts Adjustment

- a Remove the return (under) conveyor belt guard from the unit (figs. 60 and 61).
- b Adjust the return (under) conveyor drive belts in the same manner as the feeder drive belts (fig. 58).
- c Install the return (under) conveyor drive belt guard on the unit in reverse of the instructions on figures 60 and 61.

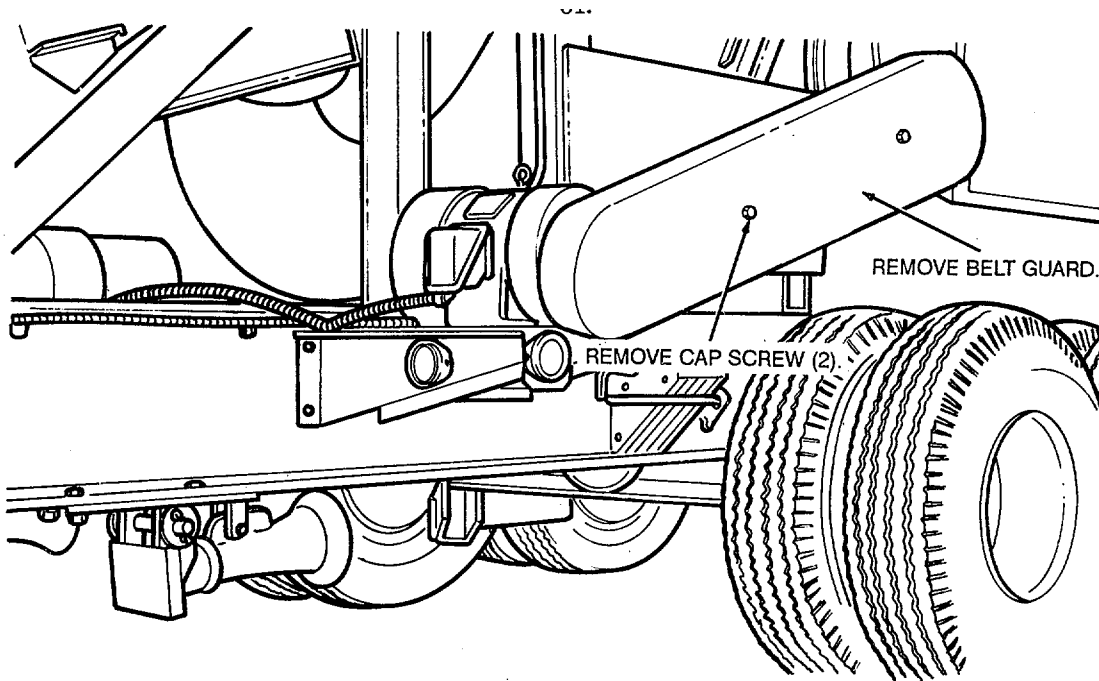

Figure 60. Return (under) conveyor drive belt guard, removal and installation

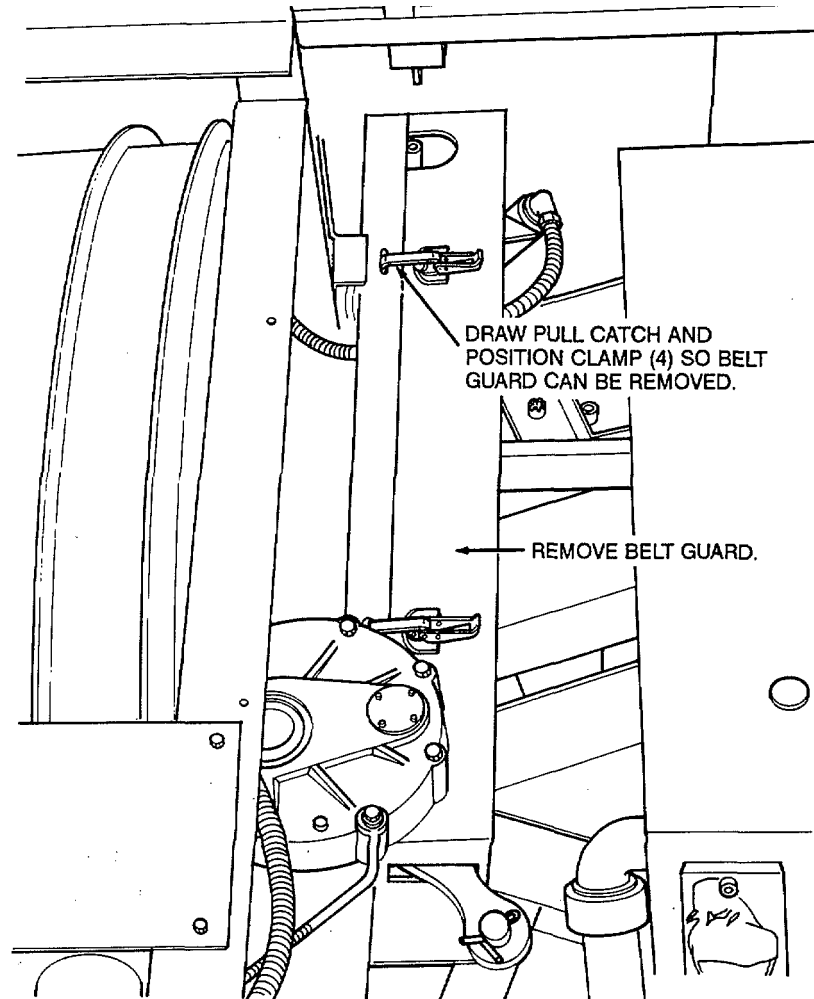

Figure 61. Return (under) conveyor drive belt guard, removal and installation (Model 5230D).

SECTION XVII. MAIN (FEED) CONVEYOR ASSEMBLY

79. General

The main (feed) conveyor assembly conveys aggregate from the feeder hopper and roll elevator to the vibrator screen assembly. The main (feed) conveyor is driven by an electric motor. Power is transmitted from the electric motor to the main (feed) conveyor by two V-belts.

80. Main (Feed) Conveyor Drive Belts Adjustment

- a. Remove the main (feed) conveyor drive belt guard from the unit (fig. 62).
- b. Adjust the main (feed) conveyor drive belts in the same manner as the feeder drive belts (fig. 58).
- c. Install the main (feed) conveyor drive belt guard on the unit in reverse of the instructions on figure 62.

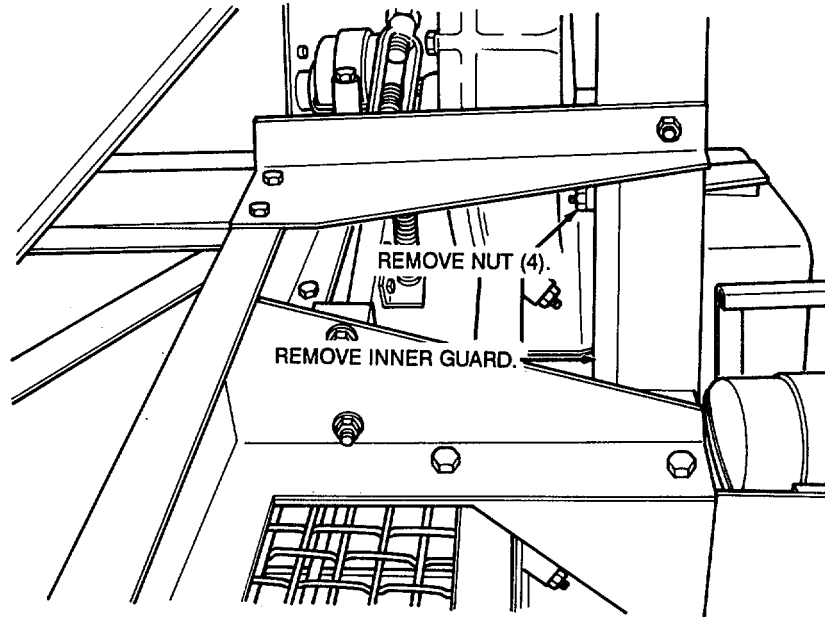

Figure 62. Main (feed) conveyor drive belt guard, removal and installation

Section XVIII. LEVELING JACKS

81. General

The leveling jacks are used to level the roll crusher for operation.

82. Cleaning and Inspection

Clean the leveling jacks and inspect for cracks, or any broken or bent parts. Check for broken or cracked welds. Put a light coat of oil on the leveling jack threads.

CHAPTER 4

DEMOLITION OF THE ROLL CRUSHER TO PREVENT ENEMY USE

83. General

When capture or abandonment of the roll crusher to an enemy is imminent, the unit commander responsible must make the decision either to destroy the equipment or to render it inoperative. Based on this decision, orders are issued which cover the desired extent of destruction. Whatever method of demolition is employed, it is essential to destroy the same vital parts of all roll crushers and all corresponding repair parts.

84. Demolition to Render the Roll Crusher Inoperative

- a. *Demolition by Mechanical Means.* Use sledge hammers, crowbars, picks, axes, or any other heavy tools which may be available to destroy the following:

Note: The following steps are the minimum require. meets for this method.

- (1) Engine block and manifolds.
- (2) Engine governor, fuel pump, and water pump.
- (3) Electric motors
- (4) Electric cables and wiring.
- (5) Conveyor belts.
- (6) The radiator and clutch housing.
- (7) The electrical control boxes. (Open doors and smash inner components.)
- (8) Gearboxes.

- b. *Demolition by Misuse.* Perform the following steps to render the roll crusher inoperative.

Note: The following steps are the minimum requirements for this method.

- (1) Drain the radiator and engine crankcase. Pour sand in the engine crankcase.
- (2) Disconnect the radiator fan and run the engine at full throttle.

85. Demolition by Explosives or Weapons Fire

a. *Explosives.* Place as many of the following charges shown in figures 63 and 64 as the situation permits and detonate them simultaneously with detonating cord and suitable detonator.

Note: The charges in steps 1 and 2 are the minimum requirements for this method.

- (1) One 1/2 lb charge on each cylinder head.
- (2) One 1/2 lb charge between injection pump and engine block.
- (3) One 1/2 lb charge on main (feed) conveyor. motor.
- (4) One 1/2 lb charge on vibrating screen vibrator.
- (5) One 1/2 lb charge on rotary elevator motor.
- (6) One 1/2 lb charge on feeder motor.
- (7) One 1/2 lb charge on return (under) conveyor motor.
- (8) One 1/2 lb charge on the vibrating screen motor.
- (9) One 1 lb charge on clutch housing.
- (10) Six 1/2 lb charges between crusher rolls.
- (11) Two 1/2 lb charges inside rotary elevator wheel.

- b. *Weapons Fire.* Fire on the roll crusher with the heaviest practical weapons available.

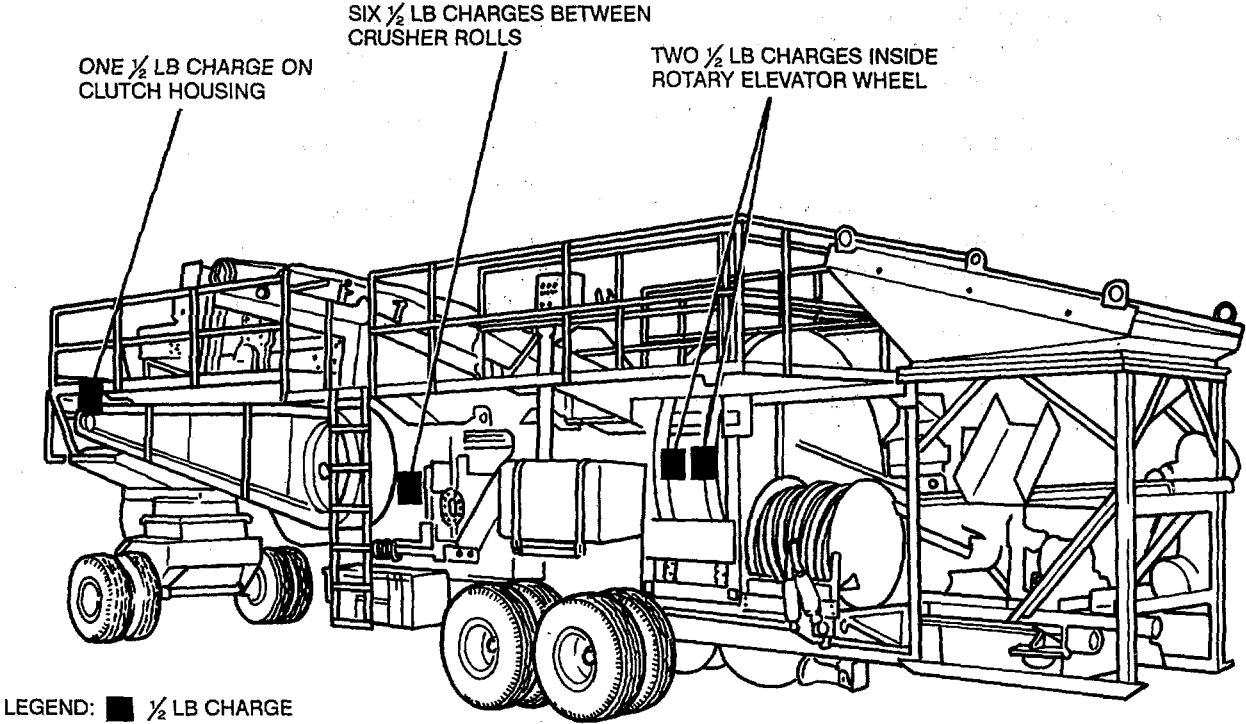

Figure 63. Placement of demolition charges, left side.

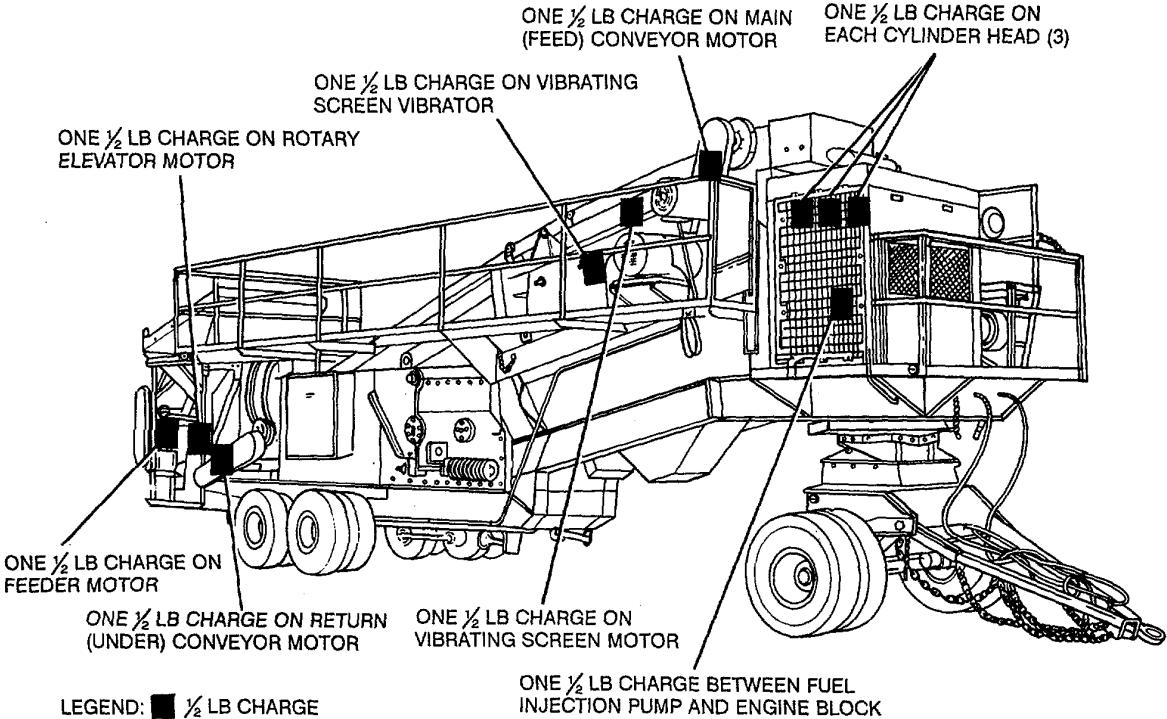

Figure 64. Placement of demolition charges, right side.

86. Other Demolition Methods

a Scattering and Concealment. Remove all easily accessible parts such as injection pump, filters, generator, starter, V-belts, electrical switches and contractors, and conveyor or belts. Scatter them through dense foliage, bury them in dirt or sand, or throw them in a lake, stream, or other body of water.

b. Burning. Pack rags, clothing, or canvas under and around the conveyor belts, tires, electric motors, fuel tank, and engine. Saturate this packing with gasoline, oil, or diesel fuel and ignite.

c Submersion. Totally submerge the roll crusher, if possible, in a body of water to create water damage and provide concealment. Saltwater will damage metal parts more than fresh water.

87. Training

All operators should receive thorough training in the destruction of the roll crusher. Refer to TM 750-244-3. Simulated destruction, using all of the methods listed above, should be included in the operator training program. It must be emphasized in training that demolition operations are usually necessitated by critical situations when time available for carrying out destruction is limited. For this reason, it is necessary that operators be thoroughly familiar with all methods of destruction of equipment and be able to carry out demolition instructions without reference to this or any other manual.

APPENDIX I**REFERENCES****1. Dictionaries of Terms and Abbreviations**

AR 310-25 Dictionary of United States Army Terms
 AR 310-50 Authorized Abbreviations and Brevity Codes

2. Fire Protection

TB 5-4200-200-10 Hand Portable Fire Extinguishers Approved for Army Users

3. Lubrication

TB 703-1 Specification List of Standard Liquid Fuels, Lubricants, Preservatives, and Related Products Authorized for Use by the U.S. Army
 LO 5-3820-205- 12- 1 Lubrication Order for Crusher, Roll: Diesel and Electric Driven, Wheel Mounted, Pneumatic Tires, 75 Ton Per Hour

4. Painting

TM 43-0139 Painting Instructions for Army Materiel

5. Preventive Maintenance

AR 750-5 Maintenance Responsibilities and Shop Operation
 DA Pam 738-750 The Army Maintenance Management System (TAMMS)
 FM 9-207 Operation and Maintenance of Ordnance Materiel in Cold Weather (0° to 65°F)
 TIM 5-3820-205-20- 1 Organizational Manual for Crusher, Roll: Diesel and Electric Driven, Wheel Mounted, Pneumatic Tires, 75 Ton Per Hour
 TM 9-2610-200-14 Operator's, Unit, Direct Support, and General Support Maintenance Manual for Maintenance, Repair, and Inspection of Pneumatic Tires and Inner Tubes
 Care,
 TM 9-6140-200-14 Operator's, Unit, Intermediate Direct Support, and Intermediate General Support Maintenance Manual for Lead-Acid Storage Batteries

6. Publication Indexes

DA Pam 25-30 Consolidated Index of Army Publications and Blank Forms

7. Training Aids

FM 101-5-1 Operational Arms and Symbols
 TM 750-244-3 Procedures for Destruction of Equipment to Prevent Enemy Use (Mobility Equipment Command)

APPENDIX II
BASIC ISSUE ITEMS LIST

Section I. Introduction

1. Scope

This appendix lists Basic Issue Items which accompany the roll crusher and are required by the operator/crew for operation, installation, or operator's maintenance.

2. General

The Basic Issue Items listed in Section II are the minimum essential items required to place the roll crusher in operation, to operate it, and to perform emergency repairs. Although shipped separately packaged, BII must tee with the roll crusher during operation and whenever it is transferred between property accounts. The illustrations will assist you with hard-to-identify items. This manual is your authority to request/requisition replacement BII, based upon TOE/MTOE authorizations of the end item.

3. Explanation of Columns

The following provides an explanation of columns in the tabular listing:

a. Column (1) - Illustration Number (Illus Number). This column indicates the number of the illustration in which the item is shown.

b. Column (2) - National Stock Number. Indicates the National Stock Number (NSN) assigned to the item and will be used for requisitioning purposes.

c. Column (3) - Description. Indicates the Federal Item Name and, if required, a description to identify and locate the item. The last line for each item indicates the Commercial and Government Entity (CAGE) Code in parentheses, followed by the part number.

d. Column (4) - Unit of Measure (U/M). Indicates the measure used in performing the actual operational/maintenance function. This measure is expressed by a two character alphabetical abbreviation (e.g., ea. in., pr).

e. Column (5) - Quantity Required (Qty Rqr'd). Indicates the quantity of the item authorized to be used with/ on the equipment.

Section II. BASIC ISSUE ITEMS LIST

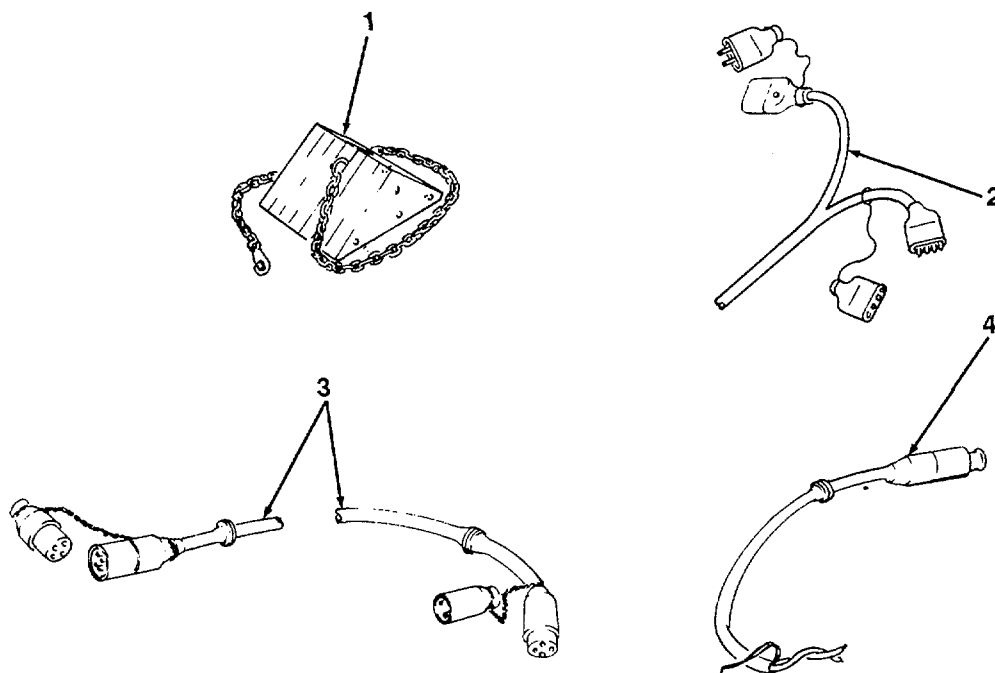

Figure 65. Basic issue items.

(1) Illus Number	(2) National Stock Number	(3) Description CAGE and Part Number	(4) U/M	(5) Qty
	6140-01-210-1964	Battery, Storage, 12 V, 6 Cell (96906) MS52149-1	ea	4
1	2540-00-670-2003	Block Chock Assembly (19207) 8343584	ea	4
2		Cable, Feeder Power (75 ft lg.) (18990) 20610	ea	1
3	6150-00-930-0559	Cable, Power (100 ft lg.) (90129) X8617-25	ea	2
4	3820-00-999-7536	Cable, Power (Pigtail) (90129) X8617-24	ea	1
	7520-00-559-9618	Case, Maintenance and Operational Manuals (81349) MIL-C-11743	ea	1

TA507917

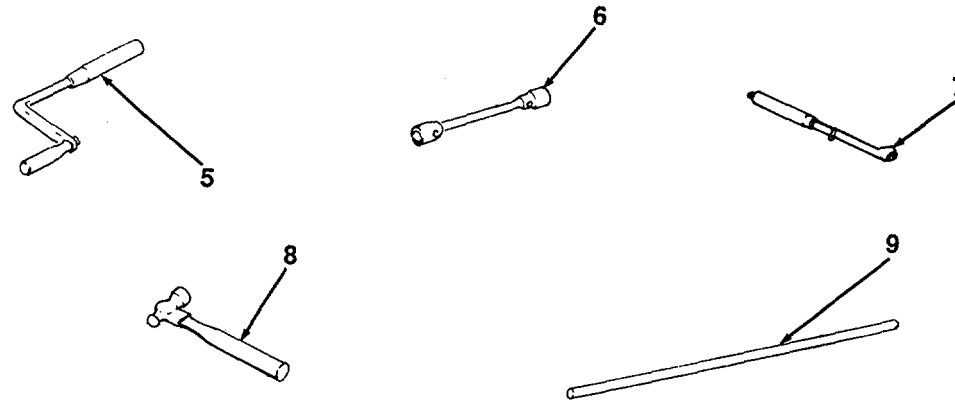

Figure 65. Basic issue items (Con't).

(1) Illus Number	(2) National Stock Number	(3) Description CAGE and Part Number	(4) U/M	(5) Qty Rqr'd
5	5340-00-937-3086	Crank, Hand, Cable Reel (92858) H-1061A-32 Department of the Army Lubrication Order LO 5-3820-205-12-1 Department of the Army Operator's Manual TM 5-3820-205-10-1 Department of the Army Organizational, Direct and General Support Maintenance Repair Parts and Special Tools List TM 5-3820-205-24P-1 Department of the Army Organizational Maintenance Manual TM 5-3820-205-20-1	ea ea ea ea	1 1 1 1
6	5120-00-227-8079	Extension, Socket Wrench 16 in. lg., 3/4 in. dr. (81348) GGG-W-461	ea	1
	4210-00-270-4512	Extinguisher, Fire, Carbon Dioxide (19207) 7714780	ea	1
7	4910-01-121-9847	Gage, Tire Pressure (55719) YA804	ea	1
8	5120-00-243-2963	Hammer, Hand (81348) GGG-W-641	ea	1

TA507918

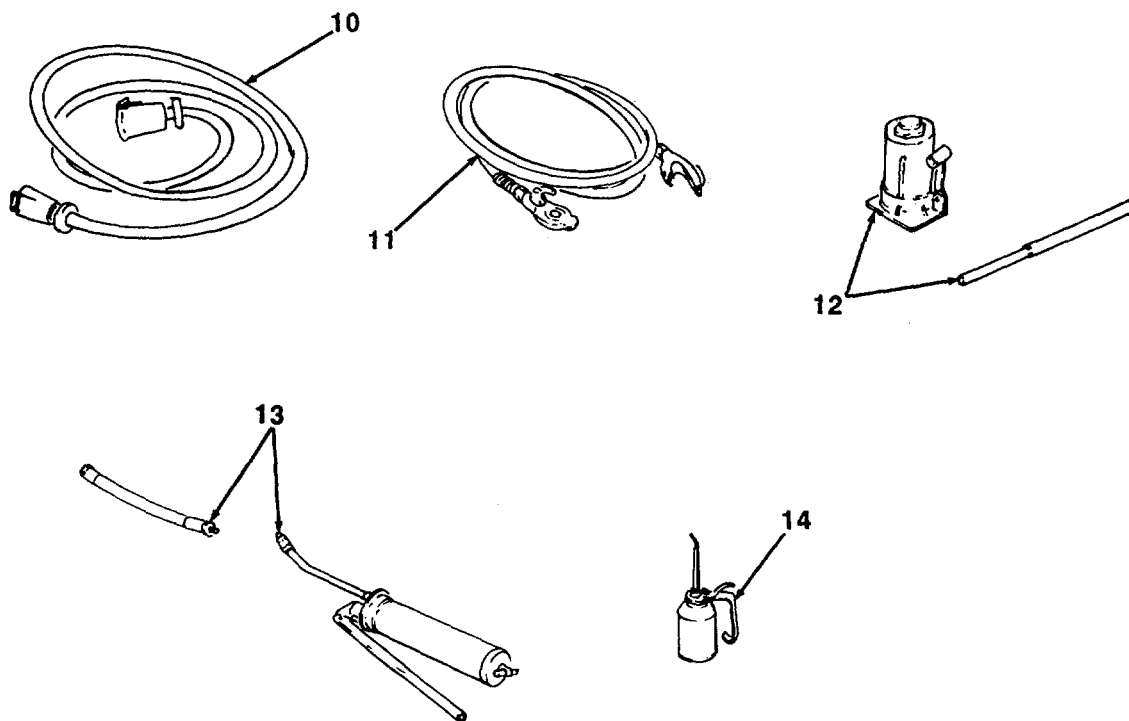

Figure 65. Basic issue items (Con't).

(1) Illus Number	(2) National Stock Number	(3) Description CAGE and Part Number	(4) U/M	(5) Qty Rqr'd
9	5120-00-709-4072	Handle, Socket Wrench 18 1/2 in. lg., 3/4 in. dr. (55719) L52BH	ea	1
10	2590-00-772-8815	Harness, Wiring (19207) 77228815	ea	1
	4720-00-703-4163	Hose, Emergency (16662) AD28139	ea	1
11	4720-00-703-4161	Hose, Service (16662) AD2611	ea	1
12	5120-01-244-7329	Jack, Hydraulic, Hand (81348) GGG-J-51	ea	1
13	4930-00-253-2478	Lubricating Gun, Hand (81349) MIL-G-3859	ea	1
14	4930-00-274-5713	Oiler, Hand (96906) MS15761-1	ea	1

TA507919

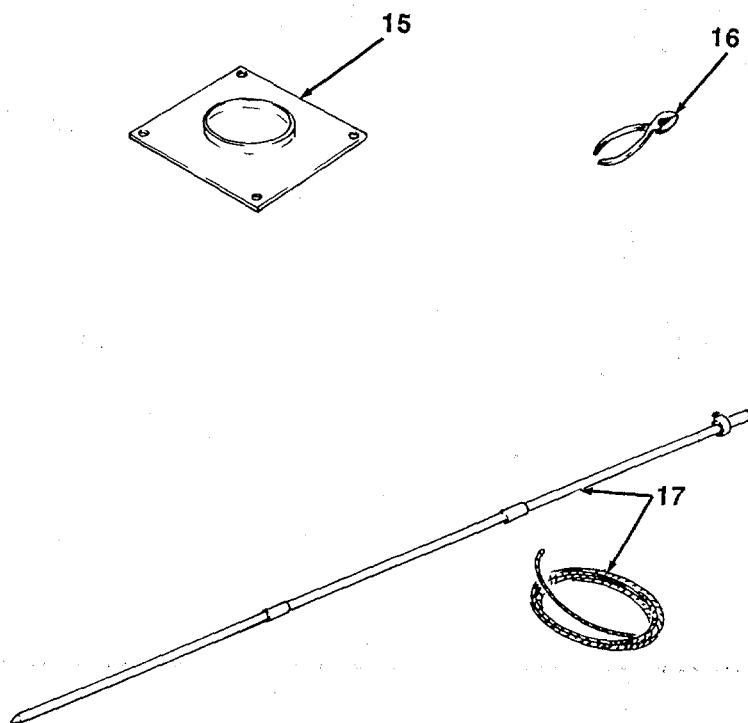

Figure 65. Basic issue items (Con't)

(1) Illus Number	(2) National Stock Number	(3) Description CAGE and Part Number	(4) U/M	(5) Qty Rqr'd
15	3820-00-930-6085	Pad, Jack (18990) 20310	ea	4
16	5120-00-223-7396	Pliers, Slip Joint (81348) GGG-P-471	ea	1
17	3820-00-930-6086	Rod, Assembly, Ground (77241) 30162	ea	3

TA507920

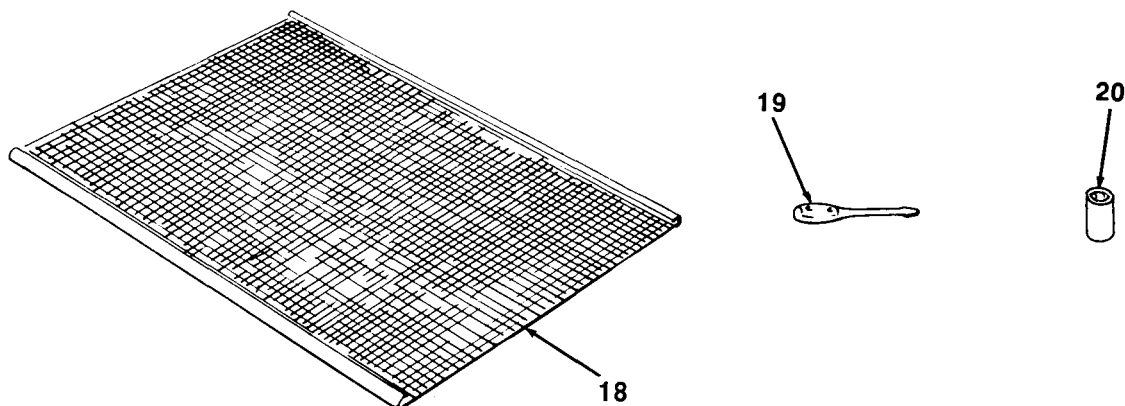

Figure 65. Basic items (Con't).

(1) Illus Number	(2) National Stock Number	(3) Description CAGE and Part Number	(4) U/M	(5) Qty Rqr'd
18	3820-00-730-5939	Screen, Roller, ¼ in. mesh (96906) MS39127	ea	2
18	3820-00-730-5938	Screen, Roller 3/8 in. mesh (96906) MS39127	ea	2
18	3820-00-730-5937	Screen, Roller, ½ in. mesh (96906) MS 39127	ea	2
18	3820-00-730-5936	Screen, Roller, ¾ in. mesh (96906) MS39127	ea	2
18	3820-00-730-5935	Screen, Roller, 1 in. mesh (96906) MS39127	ea	2
18	3820-00-730-5934	Screen, Roller, 1 ½ in. mesh (96906) MS39127	ea	2
18	3820-00-730-5933	Screen, Roller, 2 in. mesh (96906) MS39127	ea	2
18	3820-00-730-5932	Screen, Roller, 2 ½ in. mesh (96906) MS39127	ea	2
19	5120-00-236-2092	Screwdriver, Flat Tip (81348) GGS121TYPE1	ea	1
20	5120-00-199-7767	Socket, Socket Wrench 1 ¾ in. x ¾ in. dr. (58536) A-A-1394	ea	1
	6810-00-249-9345	Sulfuric Acid, Electrolyte (19207) 10875529	gl	8

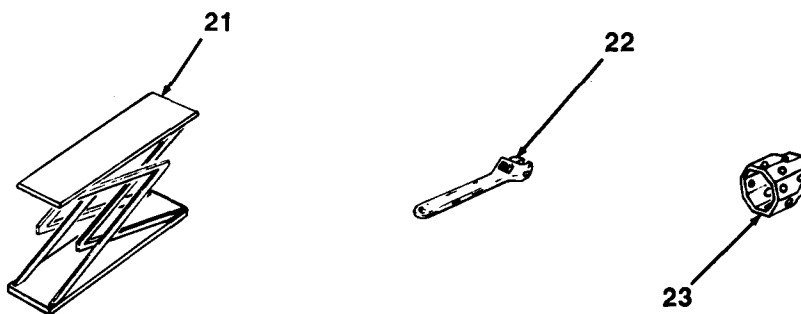

Figure 65. Basic issue items (Con't).

(1) Illus Number	(2) National Stock Number	(3) Description CAGE and Part Number	(4) U/M	(5) Qty Rqr'd
21	4910-00-262-0392	Trestle, Motor Vehicle (81349) MIL-T-14521	ea	1
22	5120-00-240-5328	Wrench, Adjustable (19207) 11655778-3	ea	1
22	5120-00-240-1414	Wrench, Adjustable (81348) GGG-W-631	ea	1
23	5120-00-393-0560	Wrench, Wheel Bearing (19207) 8390299	ea	1

TA507922

INDEX

Subject	Paragraph	Page
A		
Adjustment:		
Crusher Rolls	69	47
Feeder Drive Belts	74	51
Main (Feed) Conveyor Drive Belts	80	54
Return (Under) Conveyor Drive Belts	78	53
Rotary Elevator Drive Belts	76	52
Vibrating Screen Drive Belt	71	48
Aggregate Crushing and Screening Plant	4	3
Air Cleaner	56	41
Air brake System	63	46
B		
Brake, Air, System	63	46
C		
Carbon Dioxide Type Fire Extinguisher	23	30
Clutch Assembly, Engine	67	47
Cold Weather Starting Aids	25	30
Controls and Instruments	12	17
Cooling System, General	58	43
Crusher Rolls Adjustment	69	47
D		
Data:		
Identification	5	3
Tabulated	5	3
Demolition:		
By Explosives or Weapons Fire	85	57
Other Methods	86	59
To Render the Roll Crusher Inoperative	84	57
Training	87	59
Detailed Lubrication Information	29	31

INDEX

Subject	Paragraph	Page
Differences Between Models	6	6
Drive Belts Adjustment:		
Feeder	74	51
Main (Feed) Conveyor	80	54
Return (Under) conveyor	78	53
Rotary Elevator	76	52
Vibrating Screen	71	48
Dry Chemical Type Fire Extinguisher	24	30
E		
Engine:		
Clutch Assembly	67	47
Electrical System, General	60	44
Starting	14	22
Stopping	15	24
Exhaust System, General	64	47
F		
Feeder Drive Belts Adjustment	74	51
Field Expedient Repairs, General	50	40
Fire Extinguisher:		
Carbon Dioxide Type	23	30
Dry Chemical Type	24	30
Fuel:		
Filter.....	55	40
Tank, Strainer, Lines and Fittings	57	41
G		
General Lubrication Information	28	31
H		
Hoses, Lines, Fittings, Water Pump, Fan and Belts, Radiator	59	43

INDEX

Subject	Paragraph	Page
I		
Identification Data	5	3
Inspecting and Servicing Equipment	8	7
Installation or Setting-Up Instructions	9	7
Instruments and Controls	12	17
L		
Lubrication Information:		
Detailed	29	31
General	28	31
M		
Main (Feed) Conveyor Drive Belts Adjustment	80	54
Maintenance and Operating Supplies	Table 1	8
Models, Differences Between	6	6
Movement to a New Work site	10	15
O		
Operating Supplies, Maintenance and	Table 1	8
Operator/Crew PMCS	32	33
P		
PMCS, Operator/Crew	32	33
R		
Radiator, Hoses, Lines, Fittings, Water Pump, Fan and Belts	59	43
Return (Under) Conveyor Drive Belts Adjustment	78	53
Rotary Elevator Drive Belts Adjustment	76	52

INDEX

Subject	Paragraph	Page
S		
Screening Plant, Aggregate Crushing and	4	3
Setting-Up instructions	9	7
Starting:		
Aids, Cold Weather	25	30
Engine	14	22
Stopping the Engine	15	24
Strainer, Lines and Fittings, Fuel Tank	57	41
Supplies, Maintenance and Operating	Table 1	8
T		
Tabulated Data	5	3
Troubleshooting Procedures, General	33	37
U		
Unloading the Roll Crusher	7	7
V		
Vibrating Screen:		
Drive Belts Adjustment	71	48
Replacement	72	49
W		
Water Pump	59	43
Work site, Movement to a New	10	15

By Order of the Secretary of the Army:

GORDON R. SULLIVAN
General, United States Army
Chief of Staff

Official:

PATRICIA P. HICKERSON
Brigadier General, United States Army
The Adjutant General

Distribution:

To be distributed in accordance with DA Form 12-25-E (Block 0592) Operator maintenance requirements for TM5
3820-205-10-1.

RECOMMENDED CHANGES TO EQUIPMENT TECHNICAL PUBLICATIONS

 <p style="font-size: small; margin: 0;"><i>THEN...JOT DOWN THE DOPE ABOUT IT ON THIS FORM. CAREFULLY TEAR IT OUT, FOLD IT AND DROP IT IN THE MAIL.</i></p>		SOMETHING WRONG WITH PUBLICATION	
		FROM: (PRINT YOUR UNIT'S COMPLETE ADDRESS)	
		DATE SENT	
PUBLICATION NUMBER		PUBLICATION DATE	PUBLICATION TITLE
BE EXACT PIN-POINT WHERE IT IS			
PAGE NO.	PARA-GRAPH	FIGURE NO.	TABLE NO.
IN THIS SPACE, TELL WHAT IS WRONG AND WHAT SHOULD BE DONE ABOUT IT.			
PRINTED NAME, GRADE OR TITLE AND TELEPHONE NUMBER			SIGN HERE

DA FORM 1 JUL 79 **2028-2**

PREVIOUS EDITIONS ARE OBSOLETE.

P.S.--IF YOUR OUTFIT WANTS TO KNOW ABOUT YOUR RECOMMENDATION MAKE A CARBON COPY OF THIS AND GIVE IT TO YOUR HEADQUARTERS.

The Metric System and Equivalents

Linear Measure Liquid Measure

1 centimeter = 10 millimeters = .39 inch
 1 decimeter = 10 centimeters = 3.94 inches
 1 meter = 10 decimeters = 39.37 inches
 1 dekameter = 10 meters = 32.8 feet
 1 hectometer = 10 dekameters = 328.08 feet
 1 kilometer = 10 hectometers = 3,280.8 feet

1 centiliter = 10 milliliters = .34 fl. ounce
 1 deciliter = 10 centiliters = 3.38 fl. ounces
 1 liter = 10 deciliters = 33.81 fl. ounces
 1 dekaliter = 10 liters = 2.64 gallons
 1 hectoliter = 10 dekaliters = 26.42 gallons
 1 kiloliter = 10 hectoliters = 264.18 gallons

Weights

1 centigram = 10 milligrams = .15 grain
 1 decigram = 10 centigrams = 1.54 grains
 1 gram = 10 decigrams = .035 ounce
 1 dekagram = 10 grams = .35 ounce
 1 hectogram = 10 dekagrams = 3.52 ounces
 1 kilogram = 10 hectograms = 2.2 pounds
 1 quintal = 100 kilograms = 220.46 pounds
 1 metric ton = 10 quintals = 1.1 short tons

Square Measure

1 sq. centimeter = 100 sq. millimeters = .155 sq. inch
 1 sq. decimeter = 100 sq. centimeters = 15.5 sq. inches
 1 sq. meter (centare) = 100 sq. decimeters = 10.76 sq. feet
 1 sq. dekameter (are) = 100 sq. meters = 1,076.4 sq. feet
 1 sq. hectometer (hectare) = 100 sq. dekameters = 2.47 acres
 1 sq. kilometer = 100 sq. hectometers = .386 sq. mile

Cubic Measure

1 cu. centimeter = 1000 cu. millimeters = .06 cu. inch
 1 cu. decimeter = 1000 cu. centimeters = 61.02 cu. inches
 1 cu. meter = 1000 cu. decimeters = 35.31 cu. feet

Approximate Conversion Factors

<i>To change</i>	<i>To</i>	<i>Multiply by</i>	<i>To change</i>	<i>To</i>	<i>Multiply by</i>
inches	centimeters	2.540	ounce-inches	newton-meters	.007062
feet	meters	.305	centimeters	inches	.394
yards	meters	.914	meters	feet	3.280
miles	kilometers	1.609	meters	yards	1.094
square inches	square centimeters	6.451	kilometers	miles	.621
square feet	square meters	.093	square centimeters	square inches	.155
square yards	square meters	.836	square meters	square feet	10.764
square miles	square kilometers	2.590	square meters	square yards	1.196
acres	square hectometers	.405	square kilometers	square miles	.386
cubic feet	cubic meters	.028	square hectometers	acres	2.471
cubic yards	cubic meters	.765	cubic meters	cubic feet	35.315
fluid ounces	milliliters	29.573	cubic meters	cubic yards	1.308
pints	liters	.473	milliliters	fluid ounces	.034
quarts	liters	.946	liters	pints	2.113
gallons	liters	3.785	liters	quarts	1.057
ounces	grams	28.349	liters	gallons	.264
pounds	kilograms	.454	grams	ounces	.035
short tons	metric tons	.907	kilograms	pounds	2.205
pound-feet	newton-meters	1.356	metric tons	short tons	1.102
pound-inches	newton-meters	.11296			

Temperature (Exact)

°F	Fahrenheit temperature	5/9 (after subtracting 32)	Celsius temperature	°C
----	---------------------------	-------------------------------	------------------------	----

PIN: 025275-000